



Regent · Royale · Rosette · Regal

Assembly Instructions

GREENHOUSE

Robinsons Greenhouse Base Plan

We cannot emphasize how important it is to have a proper base for your Robinsons Greenhouse to be erected upon. It is essential that the **BASE IS FLAT, LEVEL AND SQUARE AS WELL AS BEING SUBSTANTIAL** enough to take the weight of the greenhouse including 4mm glass.

Ideally the base should be a concrete perimeter footing a spade's width and of sufficient depth for your local ground conditions. A brick perimeter base is equally suitable (and more attractive) providing there is a concrete foundation beneath it. We suggest only quality stock bricks or semi-engineering bricks are used.

This is a copy of our greenhouse base plan incorporating external dimensions only.

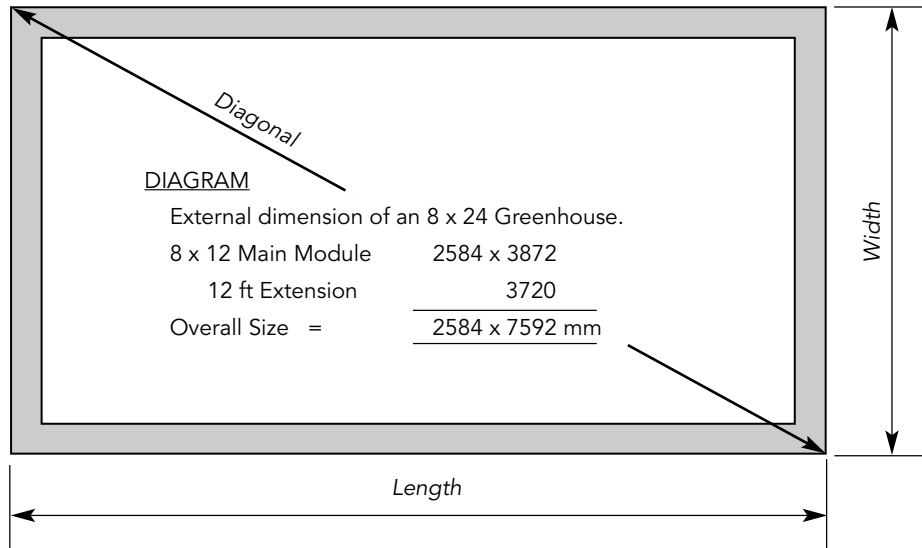

NOTE: When calculating the length of a unit that has an extension you must add the main module dimension to give you the overall length. See diagram above.

NOTE: For Lean-To models less an end deduct 67mm from length.

Dimensions shown are all external and allow for a small overhang, as shown in diagram below, suitable for brick or concrete perimeter bases.

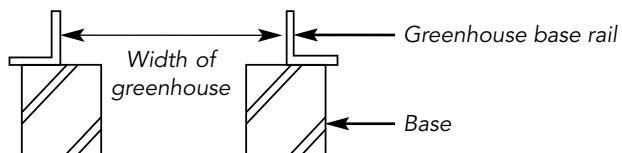

NOTE: If the prepared base is larger than these sizes then a seal must be made between base rail and concrete.

EXTERNAL DIMENSIONS (mm)

MODEL	Width	Length	Diagonal
6 x 6	1964	2012	2812
6 x 8	1964	2632	3284
6 x 10	1964	3252	3799
6 x 12	1964	3872	4342
8 x 6	2584	2012	3275
8 x 8	2584	2632	3688
8 x 10	2584	3252	4154
8 x 12	2584	3872	4655
10 x 8	3208	2632	4150
10 x 10	3208	3252	4568
10 x 12	3208	3872	5028
12 x 8	3824	2632	4642
12 x 10	3824	3252	5020
12 x 12	3824	3872	5442
6ft ext.	-	1860	-
8ft ext.	-	2480	-
10ft ext.	-	3100	-
12ft ext.	-	3720	-

Model sizes listed are nominal.
 ie: an 8x 10 is the model 8'6" x 10'8"

THE BASE MUST BE FLAT, LEVEL AND SQUARE

CONTENTS PAGE NO.

General order of assembly	3
Assembly of roof sides and ends	4/5
Assembling the vent	6
Positioning the vent	7
Glazing the roof	7
Glazing the sides	8
Glazing the ends	9
Fitting the door frame	9
Assembling the doors	10
Fitting the doors	11
Final finishings	12
Fitting extensions and partitions	12/13
Securing the base	14/15
Identification Charts	16/17/18
Glazing Plans	19/20/21
3 Slat Staging assembly instruction	22
7 Slat Staging assembly instruction	23
10 Slat Staging assembly instruction	24
Louvre installation instruction	25
Plates assembly instruction	26
'A' Frame assembly instruction	27

General order of assembly

1. Assemble Roof
2. Assemble Sides with Roof
3. Assemble the Gable Ends
4. Assemble the Vent
5. Glaze the Roof
6. Fit Vent
7. Glaze the Sides
8. Glaze the Plain End
9. Glaze the Door End up to door aperture (not above)
10. Fit the Door Frame
11. Assemble the Door(s)
12. Fit the Doors
13. Final Finishing
14. Securing the Base

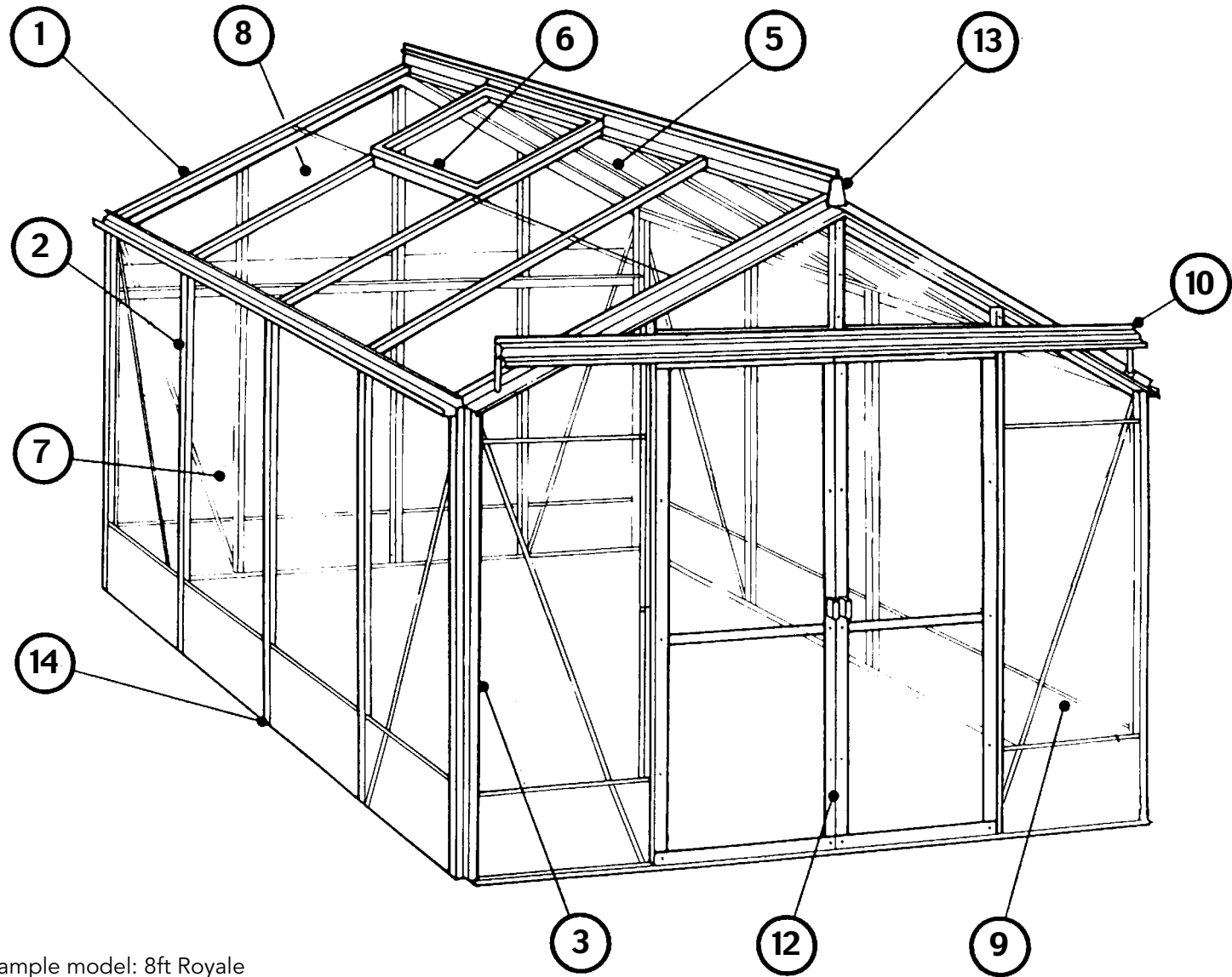

Example model: 8ft Royale

REGAL
SEE PAGE 15
To be read in conjunction
with main assembly
instructions

ASSEMBLY OF ROOF, SIDES & ENDS

NOTE: IDENTIFICATION OF ALL PARTS AND SECTIONS CAN BE FOUND ON THE ID CHARTS (PAGES 16 – 18).

THE ROOF

- 1 Identify the ridge member (no.1 on ID chart), roof glazing bars (No. 2 ID chart), roof end glazing bars (No. 3) and the eaves gutter (No. 4). For help with identification, roof glazing bars are the same length as roof end glazing bars.
- 2 Thread PVC glazing strip (No. 5 ID chart) into the grooves provided on the roof glazing bars and the inside groove of the roof end bars. Cut to full length taking care not to stretch the PVC strip. Water or washing up liquid used as a lubricant may help; especially in winter months.

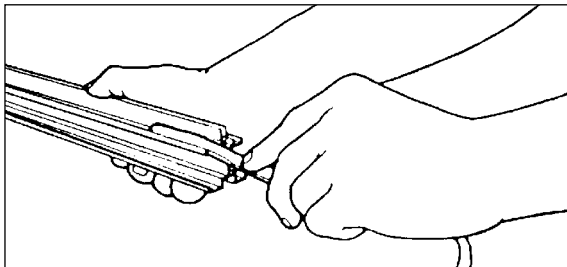

- 3 The roof is assembled upside down initially. Lay out the parts roughly in position with PVC strip facing downwards.

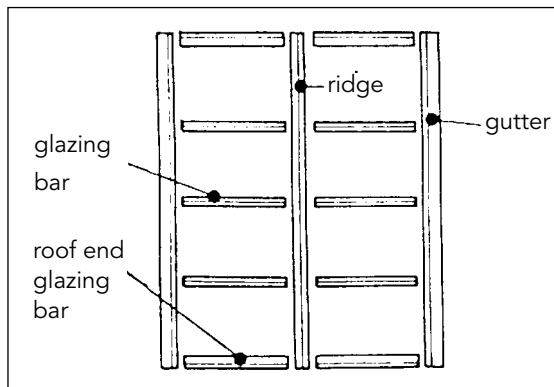

NOTE: If fitting a partition or extension read in conjunction with Pages 13.

4. Insert short square headed bolts (No. 6 ID chart) into the holes provided in the ridge member and loosely fit nuts.

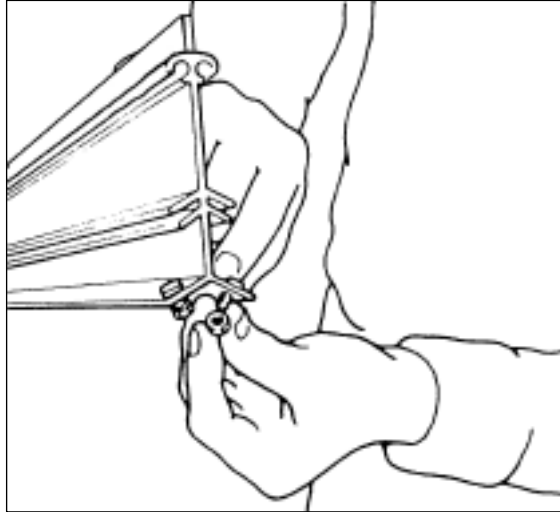

5. Starting with one side only, slide glazing bars and roof end glazing bars onto bolt heads and push home fully. Tighten nuts securely taking care not to over tighten.

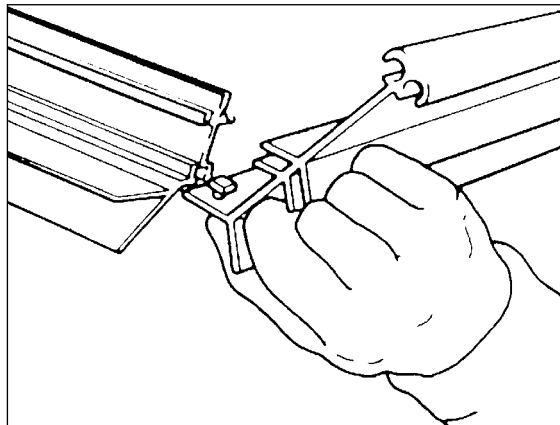

6. Repeat process for the other side.
7. Fit apex plate (No. 7, ID chart) to both ends as shown and

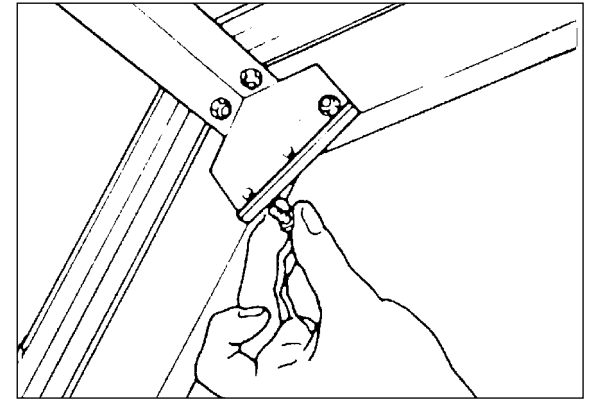

tighten securely.

8. Starting with one side only, slide one short bolt into the

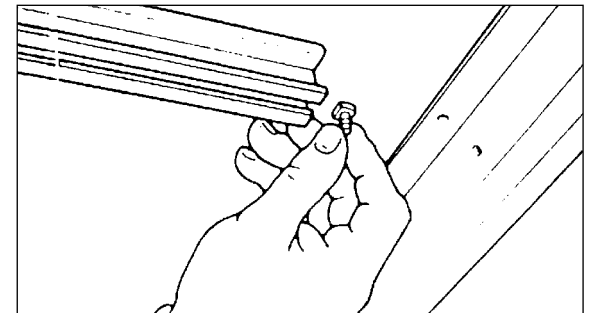

ends of roof glazing bars and roof end glazing bars.

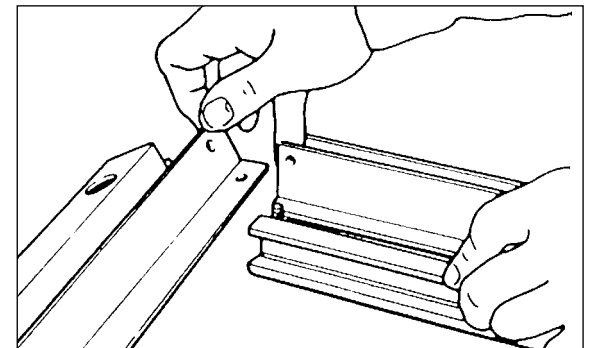

9. Offer up eaves gutter to bolts and, taking care to push fully home, tighten securely both roof end glazing bars.
10. Repeat instructions 8 and 9 for other side.
11. Turn completed assembly over.

NOTE: It would be most advisable to obtain assistance in carrying out instruction 11 - particularly with larger buildings.

THE SIDES

12. Identify Side and Corner Glazing Bars (Nos. 2 and 8, ID Chart) and lay out roughly in position. Thread PVC Glazing Strip into the grooves provided in all glazing bars. Fit PVC strip only to the inside grooves of corner glazing bars.

NOTE: If fitting a partition or extension read in conjunction with pages 11.

13. Loosely fit nuts and bolts in all remaining holes in the roof assembly taking care that square bolt heads face outward. Fit long bolts (No. 9, ID Chart) in the end holes of each eaves gutter and in the bottom hole of each roof end glazing bar. A strengthening brace will be fitted to the long bolts at a later stage.
14. Lifting one side of the roof assembly only, slide a centre intermediate glazing bar onto the previously fitted bolt in the eaves gutter. Tighten nut securely.

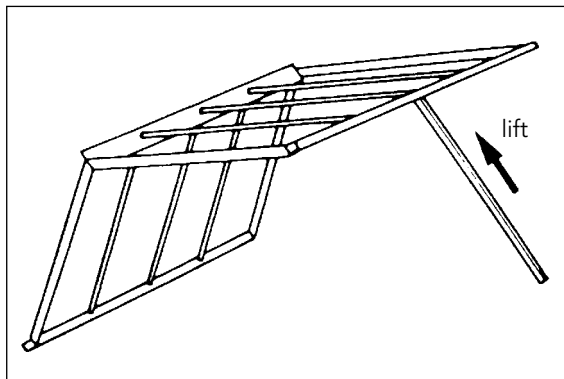

15. Fit remainder of intermediate glazing bars to the same side.
16. Slide corner glazing bars (No. 8, ID Chart) onto the bolts previously fitted in end of gutter and bottom of roof end glazing bar.

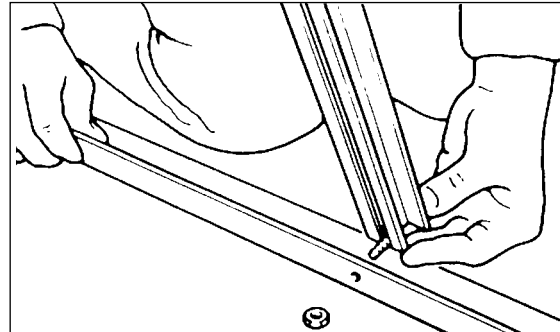

17. If fitting a louvre, slide two short bolts up each adjoining side glazing bars and secure with nuts. Then slide long bolts up each of the side glazing bars (including corners) and lock temporarily in position.
18. Identify side base rail (No.10, ID Chart), place in position, then attach using bolts temporarily locked in glazing bars.

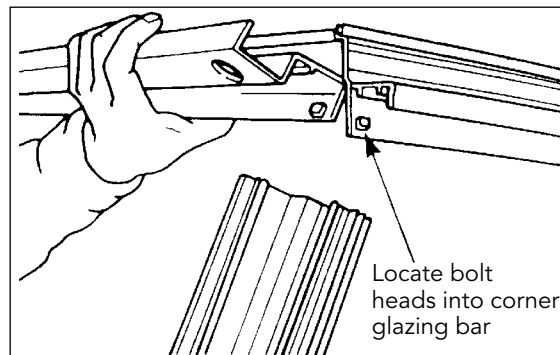

19. Lift other side of greenhouse, fit centre glazing bar and proceed as for previous side until complete.
20. Fit two diagonal braces to each side as shown on page 1. The long bolts at the top of the corner glazing bar and at the bottom of the glazing bars will be long enough to accommodate the brace. The sides are now complete.

PLAIN END AND DOOR END

21. Identify end gable base rail. (No. 11, ID Chart) and loosely fit long bolt to end holes
22. Fit corner glazing bars onto gable base rail (door end) as shown and secure.

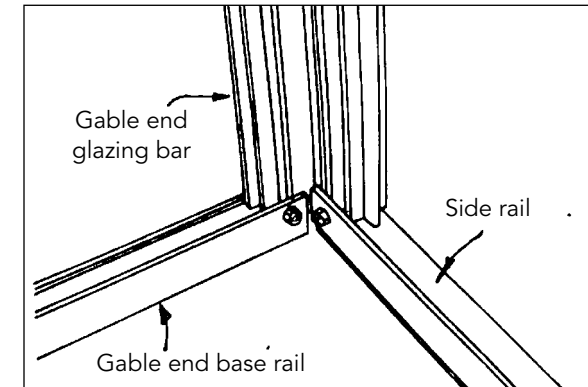

23. Identify plain end gable base rail (No.11, ID Chart) and, remembering to slide an additional short bolt into corner (Gable end side) glazing bars (Royale & Rosette only) for fitting plain end purlin at later stage. Repeat procedure as for door end base rail.
24. Identify plain end glazing bars (door end glazing bars are the same) and slide up onto bolts in roof end glazing bars and apex plate as appropriate. For Regent models no centre glazing bar is fitted.

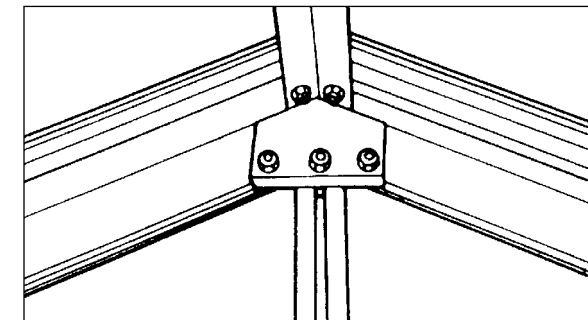

25. Slide a short bolt approximately 1/2 way up each bar and temporarily lock in position (Royale & Rosette only).

Then slide a long bolt into the end glazing bars and attach the long bolt to the base angle as shown. Secure end glazing bars top and bottom.

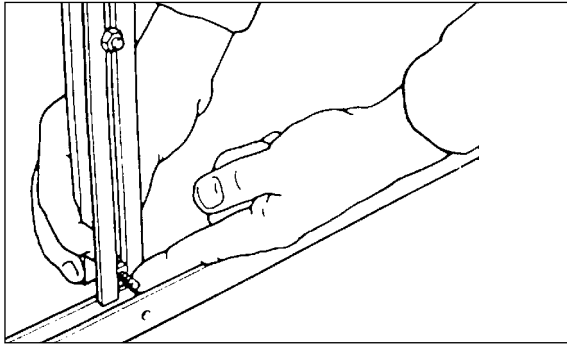

26. Identify door end glazing bars (No. 2, ID Chart). Proceed as for plain end glazing bars, remembering to slide an additional short bolt up each glazing bar. Do not at this stage fix the short centre glazing bar, (on Royale & Rosette models).
27. Next fit the door guide (No.11, ID Chart) & threshold (No. 51, ID Chart) onto the base rail, position the door guide as below. Then push down firmly on the threshold until it locks into position.

8’/10’ Door end

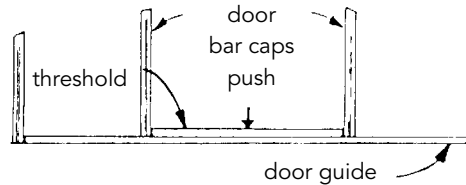

6’ Door end

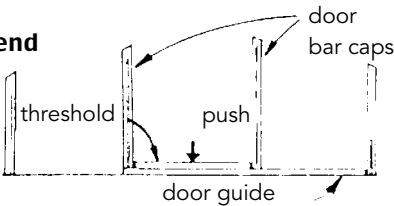

28. Fit braces to both gable ends as shown. Fit tubular roof ties (Royale and Rosette only) fit tubular eaves braces (Rosette only) equidistant along the length of the house, to the roof glazing bars using cropped head bolts and nuts (No.24, ID Chart).

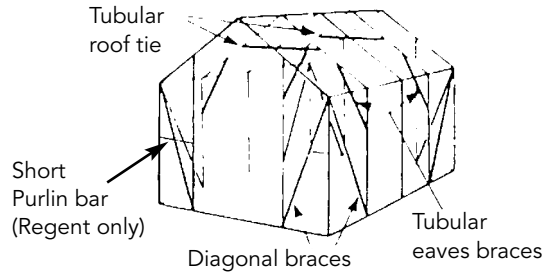

29. Identify plain end purlin member (No.12, ID Chart) (Not required on Regent Model) and using short bolts previously fitted, offer up purlin to end and corner glazing bars. Secure horizontal purlin approximately 250mm (10”) down from eaves. The corner braces should pass behind the purlin.

On REGENT ONLY fit short purlin to left hand side of door end and temporarily fix the strike plate at this stage. (see page 78. Square bolts and nuts in glazing bar).
NOTE: With the basic framework complete the next stage is to check with a spirit level that the structure is plumb, level and square in all planes before glazing.

30. Fit eaves rail / gutter closure, (see No. 59, ID Chart).

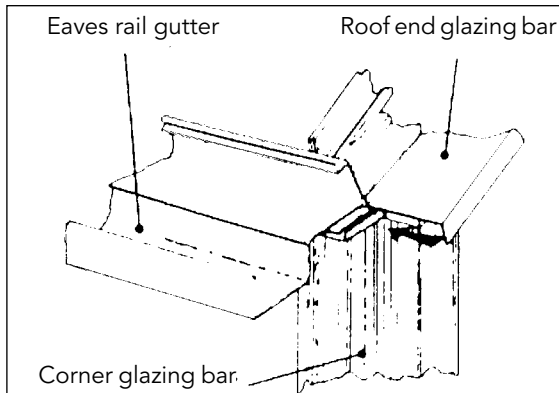

Insert closure as shown and push fully home (A small amount of water or washing up liquid may help)

NOTE: These closures are supplied in pairs and must be separated by cutting with scissors or a knife before being inserted.

ASSEMBLING THE VENT

31. Identify vent kit(s) and assemble with a standard size pane of glass (610 X 610). Do not at this stage attach the slam rail assembly, this will be attached when the roof glazing is complete. (Stage 40)

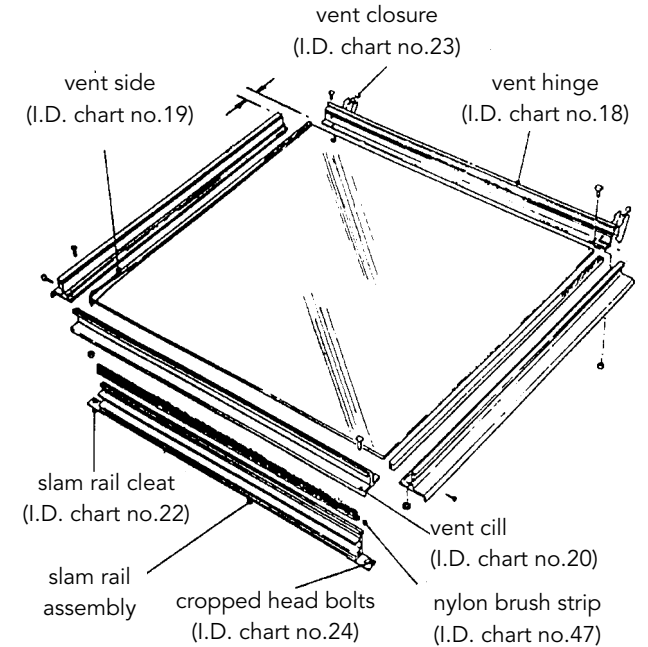

32. Fit both side vent members to vent hinge, using M6 x 10 bolts. Slide glass into side vents and into hinge. Then fit cill member in place and fix using M6 X 10 bolts. Finally, using No. 8 X 12 self tapping screws, fix at each corner, ensuring the vent hinge closures are in place.

On all models use silicone around the perimeter of the glass to seal any gaps, checking first that the vent is square.

POSITIONING THE VENT

NOTE: Before glazing it is advisable to separate the various bar caps and covers, the side bar caps, the gable end bar caps and the bar caps for the roof. The roof bar caps come in 2 lengths, the covers in one.

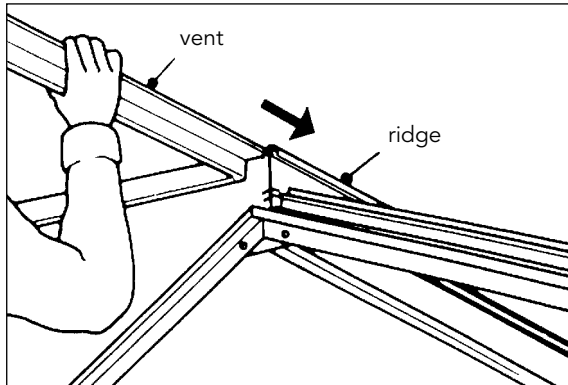

33. At this point the roof vent and vent stops must be slid into the groove provided in the ridge (a vent stop either side) and located over your chosen vent aperture, do not tighten the vent stops at this stage. (as drawing above).

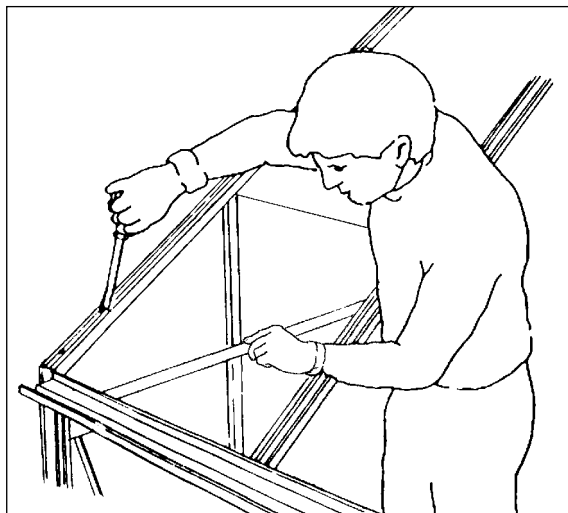

RIDGE CRESTING AND FINIALS NEED TO BE POSITIONED BEFORE GLAZING THE ROOF.

ONLY 'MALE' FINIALS ARE SUPPLIED. THE TONGUE NEEDS TO BE REMOVED FROM ONE OF THEM AND ALSO THE LAST PIECE OF CRESTING TRIMMED TO GET THE CORRECT FINISHED LENGTH. THE MODIFIED FINIAL CAN BE FIXED WITH SOME SILICONE.

GLAZING THE ROOF

Please refer to glazing plans.

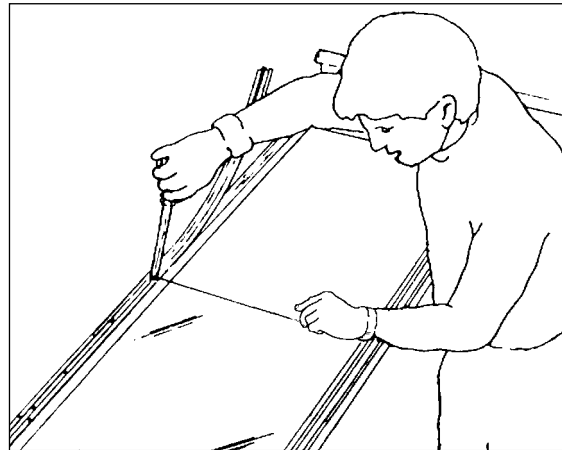

34. Starting with one side of the roof and with reference to the glazing plans identify the glass required and a corner bar cap (No. 14, ID Chart), position the first pane of glass and secure bottom of the bar cap with two self tapping screws (No.17 ID Chart). On models with a single piece of roof glass take care to feed the glass into the ridge section and fix the other length of bar capping. Finally fit the bar cap cover (No13, ID Chart).
35. For models with 2 pieces of glass in the roof position the next pane (610 x 610mm), taking care to feed the glass into the ridge section. This pane should overlap last sheet by 10mm approx, then place bar cap in

position and screw down with self tapping screws. Totally secure the bar cap using self tapping screws. Fit the bar cap cover (No.13, ID Chart)

36. Now glaze the roof section diagonally opposite (on the other side of the greenhouse) in a similar way and this will help to check that the frame is square.
37. Continue to glaze one of the sides of the roof following the same procedure, using standard roof bar caps (No. 15, ID Chart)



38. When you reach the vent position it will be necessary to slide the vent a short distance each way while the bar cap is secured.
39. To secure the roof vent raise the vent from inside the greenhouse, this will allow access for locating and fixing the vent stops.
40. Now with one side of the roof glazed and with the roof vent(s) secured repeat the glazing procedure for the opposite side.

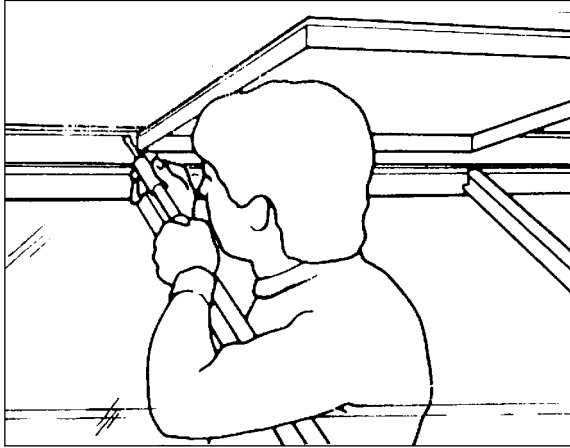

41. Identify the slam rail (from vent kit) and slide the brush strip along its length, protruding each end by approximately 5mm. Then using standard M6 X 10 bolts and nuts attach the fixing cleats (No. 22, ID Chart). Next identify 2 cropped head bolts (No. 24, ID Chart) and ensuring that they are located into the glazing bars on either side of the vent, slide rail down onto edge of glass, tighten nuts to secure.

NOTE: See separate instruction leaflet in opener box for full details.

GLAZING THE SIDES

43. With reference to the glazing plan identify glass, PVC corner bar capping, PVC standard bar capping (No. 14 and 15 ID Chart), 4mm separator strips for glass (No 25 ID Chart).
44. Bar capping will be almost the same length as side glazing bars.
45. Starting from one corner, position first 610 x 305 panel fitted with 4mm separator strip.
46. Select corner bar capping and secure with bottom self tapping screws (No.17, ID Chart) only at this stage.
47. Continue fitting the 610 x 305 panels using standard bar capping, finishing the row with another bar capping.

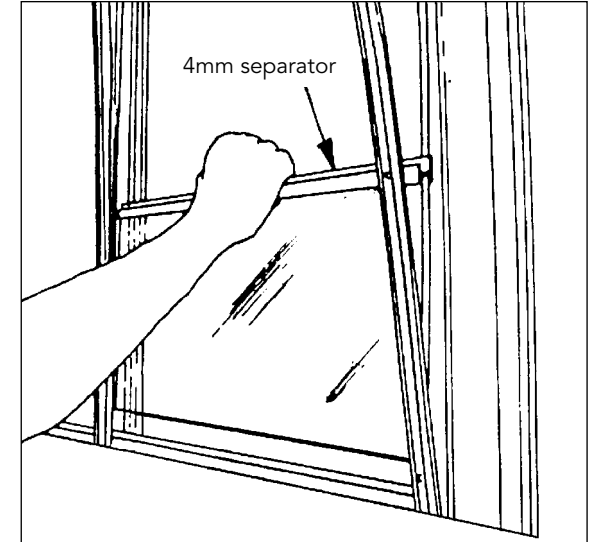
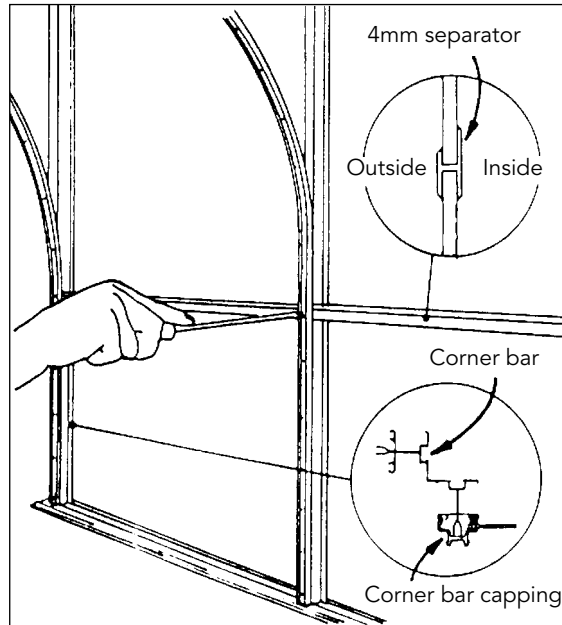

48. Fit the next sheet of glass into the 4mm separator.
49. Follow drawing to position glass under gutter.

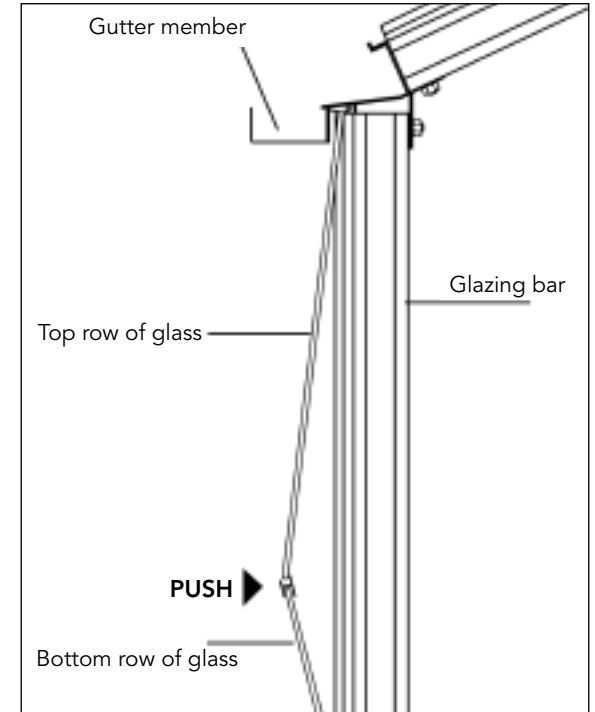

50. Secure both panes in position one side only by screwing all self tapping screws into the bar capping.
51. Repeat instructions 48 to 50 until side glazing is complete, finishing the side with a further corner bar capping. Then fit the bar cap covers, repeat the whole procedure for the other side.

GLAZING THE PLAIN END

52. Locate and roughly lay out corner bar capping and standard capping for greenhouse ends.

NOTE: Gable end corner bar caps are longer than the side bar caps.

53. Following established procedure, fit all 610 x 305 panels and all glass panes up to (but not including) the top angled sheets and secure as work proceeds. (See illustration, next column)

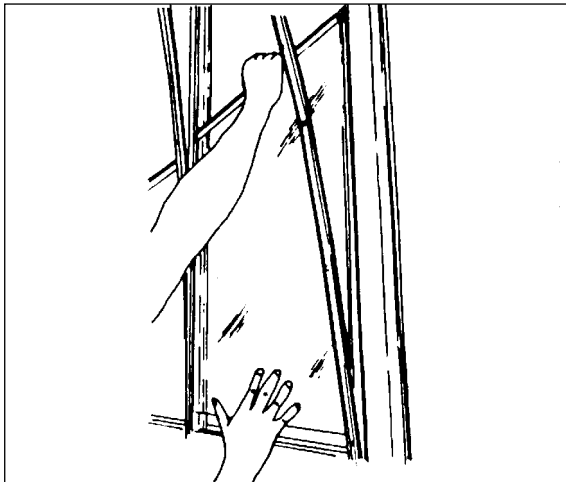

54. With reference to the glazing plan, identify the top angled pane and fit by pushing up into the roof end bar recess, and align bottom edge with separator strip allowing glass to drop in. Secure all bar capping, which on ends will tuck up under roof end bars.

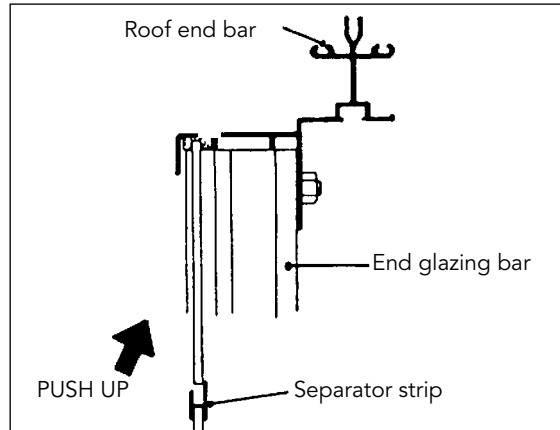

GLAZING THE DOOR END

55. The Royale and Rosette models are both supplied with double doors. The Regent differs having a single door, the fitting procedures are similar, the main difference being a strike plate for the single door (No. 70, ID Chart). Fit the strike plate temporarily at this stage half way up the glazing bar that the door will slide and lock onto.
56. With reference to the glazing plan for your model, follow the established procedure to glaze the door end, using the doorbar caps and covers (1883mm) either side of the door aperture. Fix onto the top of these the small 'S' shaped clips (No. 26, ID Chart) as shown.

NOTE: No glass can be fitted above the door opening until the door frame has been fitted.

FITTING THE DOOR FRAME

57. Identify the inner door track (No. 31, ID Chart) and centre door stop (Royale and Rosette models only) and, using short bolts, secure the stop to the track using the holes provided.

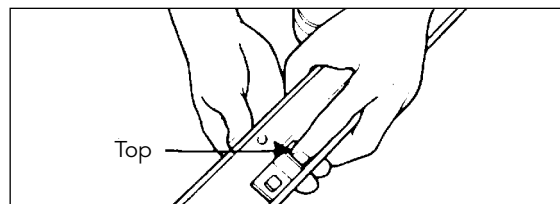

58. On the ground, assemble the outer door track (No. 33, ID Chart) and the doorway header (No.34, ID Chart) with inner track using long bolts.

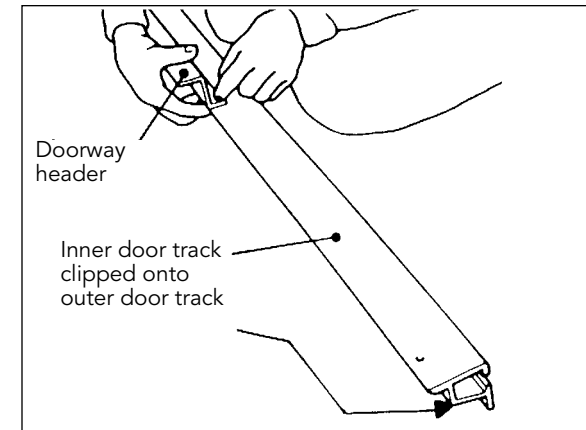

59. Identify the track support cleat (No. 35, ID Chart) and the track support (supplied but NOT required on Rosette and Regal) (No. 36, ID Chart) and attach to roof end glazing bars using long bolts as shown.

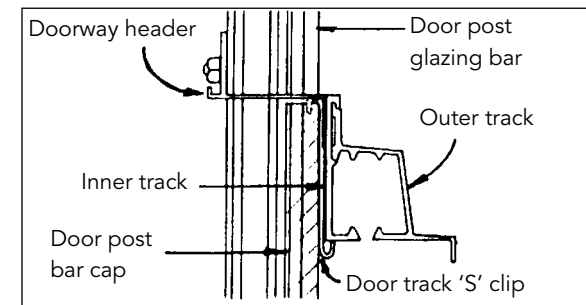
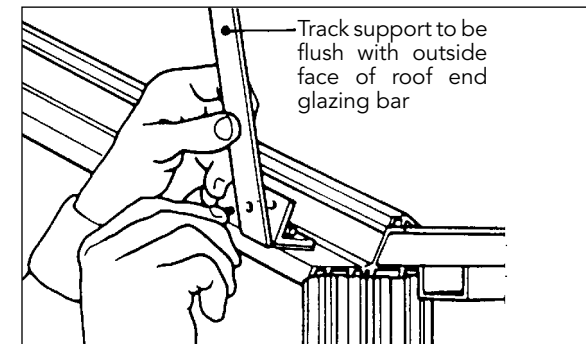

60. Offer up to the complete track assembly and attach to the track supports as shown, using long bolts. The door track should rest on the small 'S' shaped clips (No. 26, ID Chart).

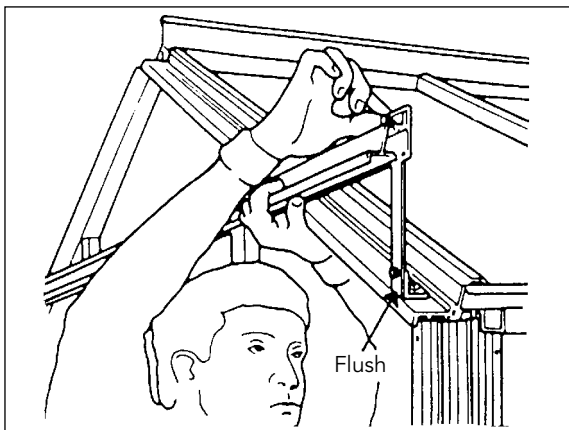

61. On the inside of the greenhouse, pick up the spare nut and bolt previously slid into the door end glazing bars and connect the doorway header attachment plate (No. 37, ID Chart) to the back of the doorway header and glazing bar using short bolts.

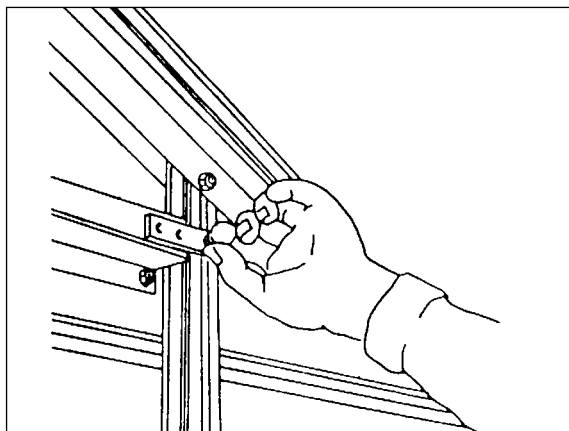

62. Identify the short central front glazing bar (Royale and Rosette only) and attach to both apex plate and doorway header using short bolts.

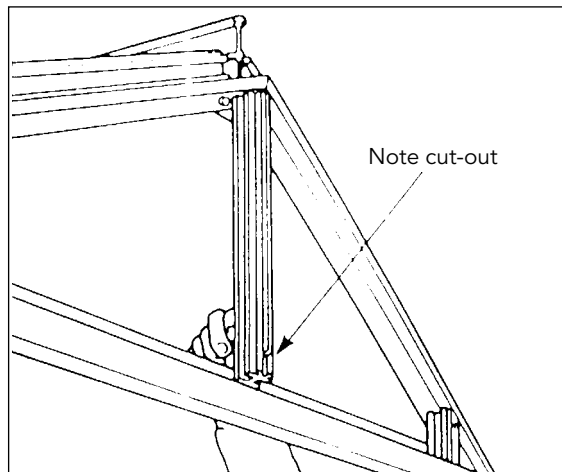

63. Identify the zed trim (No. 38, ID Chart) and position on top of the track as shown. The final apex glass can now be fitted using established procedure. Secure the zed trim and glass together with short bar capping.

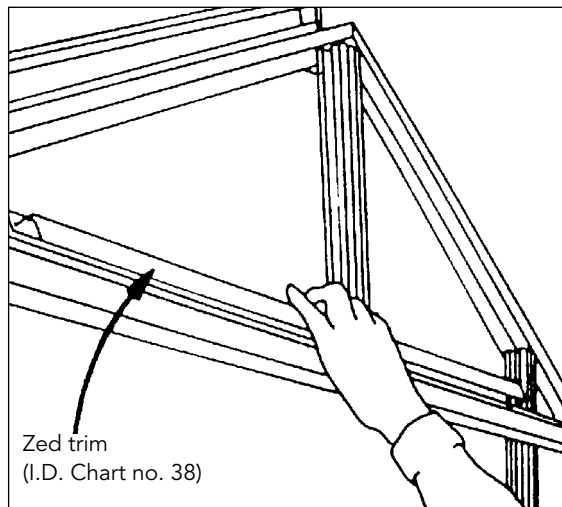

The door frame is now complete.

ASSEMBLING THE DOOR(S)

64. Identify the door side members 2 of (No. 39, ID Chart) for a single door, 3 of (No. 39, ID Chart) and 1 of (No. 40, ID Chart) for a pair of double doors, lay them on a level surface.

65. Select the bottom door crossbar (No. 41 ID Chart), position this between the side members and loosely fix using pan head bolts.

66. Slide PVC edging strips into both door sides.

67. Take bottom size (922 X 555) door sheet glass panel and slide into position between side members, so that it engages in cross bar recess.

68. Slide another door cross bar in position and bolt door to side members.

70. Select 812 X 555 mm glass pane, fit white PVC edging strip (No. 44, ID Chart) to both sides. These strips should be 8mm short at each end.

72. The top cross bar (No. 45, ID Chart) is fitted in the same way as the previous, with the wheels facing upwards.

73. Fit the nylon door glide (No. 48, ID Chart) to the bottom cross bar.

74. Repeat steps 64 to 73 for other door (if double doors required).

75. Slide the 2 nylon brush strips (No. 46, ID Chart) into groove on the door side members (2 on a single door and 1 on each side of a double set). These should seal against the door post bar caps when the doors are closed. Crimp the bottom of the groove to prevent the brush strip from sliding out.

76. Screw door side members to the top and bottom bars using self tapping screws.

77. Tighten all the pan head bolts and nuts. The strike plate (I.D. Chart No. 70) which was temporarily fitted earlier can now be fixed in its final position. Line up the hole in the plate so that the door lock engages.

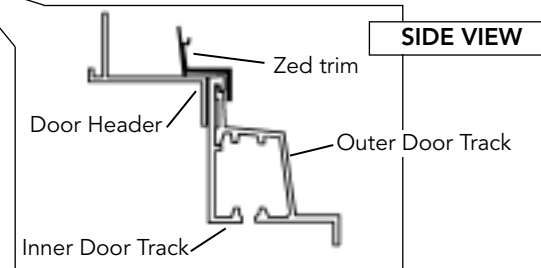

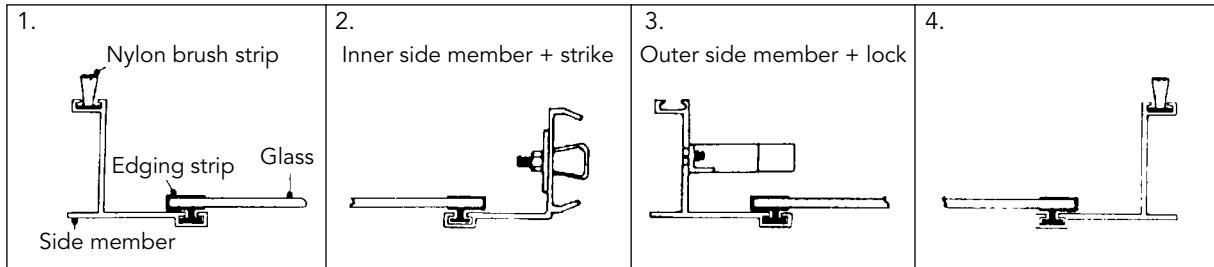

ASSEMBLING THE DOORS

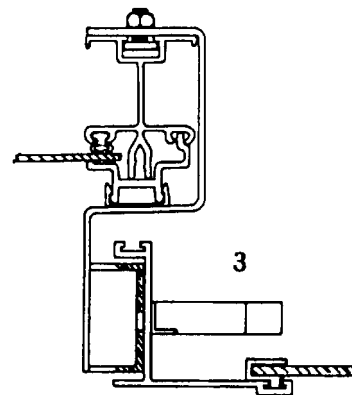
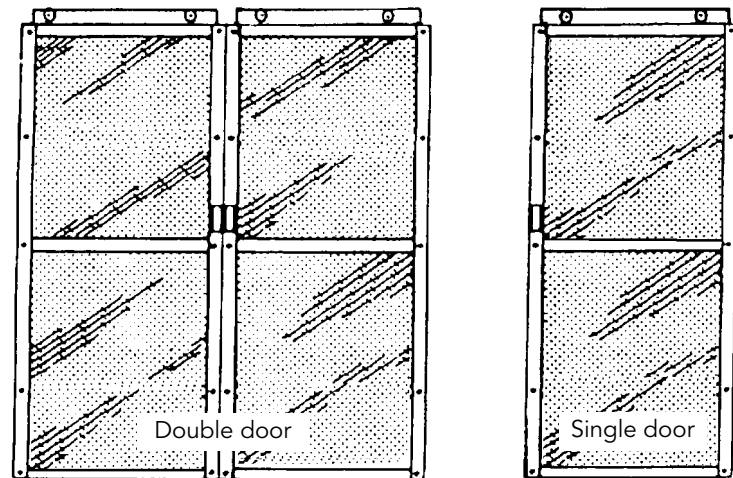

CONSTRUCTION DETAILS

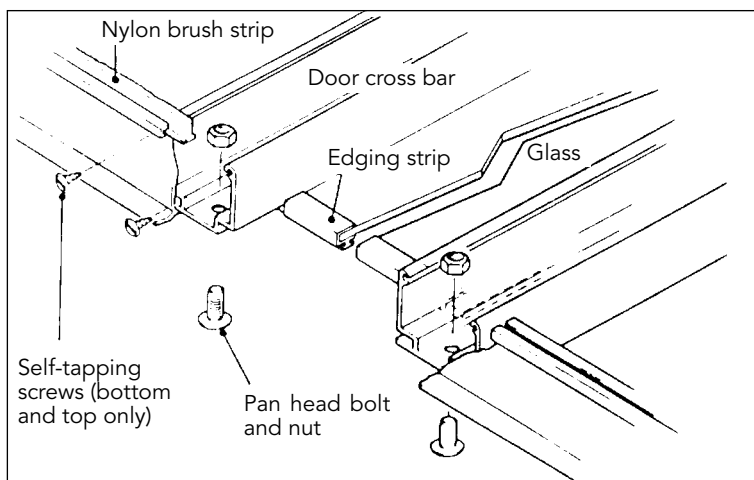

78. The strike plate (I.D. Chart No. 70) which was temporarily fitted earlier can now be fixed in its final position. Line up the hole in the plate so that the door lock engages.

FITTING THE DOORS

79. Slide door wheels into top track, at the same time ensuring the nylon door glide engages in the door guide. Slide on completely and repeat process for other door.

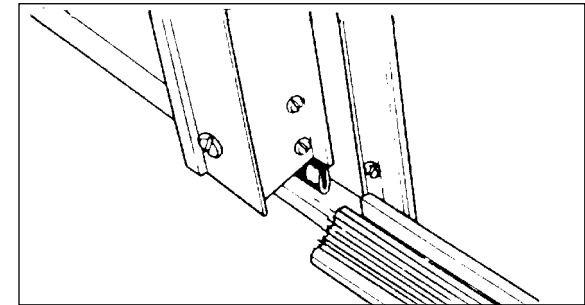
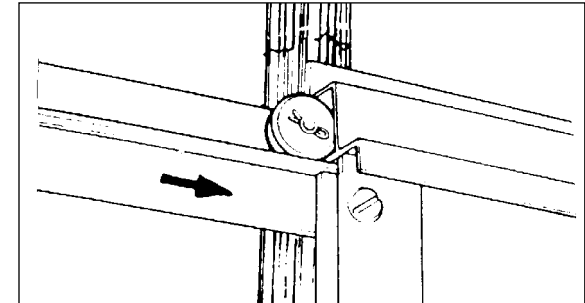

80. Check that both doors run freely, if not then check that the outer track is sitting squarely on the inner track. It may be that the centre door stop (Double doors only) is fitted incorrectly and is preventing this. Also check that door track is parallel to door guide.

81. When the doors are running to your satisfaction, fit a rubber door stop to each end of the track in the holes provided using M4 X 10mm stainless steel nut, bolt and washer.

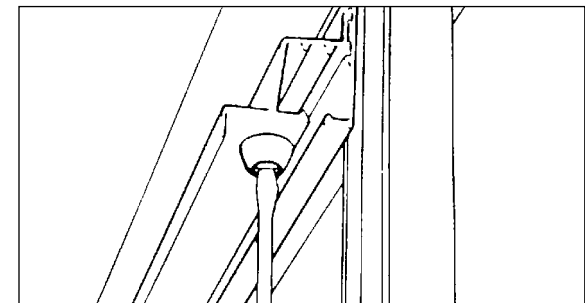

FINAL FINISHING

Your greenhouse is now basically complete and requires a few finishing touches.

82. Identify moulded door track covers and ridge finial (No. 52 & 53, ID Chart). Secure in position by pushing home plastic bosses into appropriate location points.
83. Locate gutter outlet stubs (No. 54, ID Chart) and having decided on the position for your rain water pipes, fit these at the down pipe end. Now fit the blanking grommets (No. 55, ID Chart) at the opposite end. Then fit the stop ends (No. 56, ID Chart) positioning the rounded corners into the bottom curved corners of the gutter.
84. Finally identify and fit the angled rainwater pipe outlet (No. 57, ID Chart) onto the downpipe, then fit opposite end onto the gutter stub (No. 54, ID Chart). Finish by drilling a small hole through the capping and using a No. 8 x 12 screw fix pipe bracket.

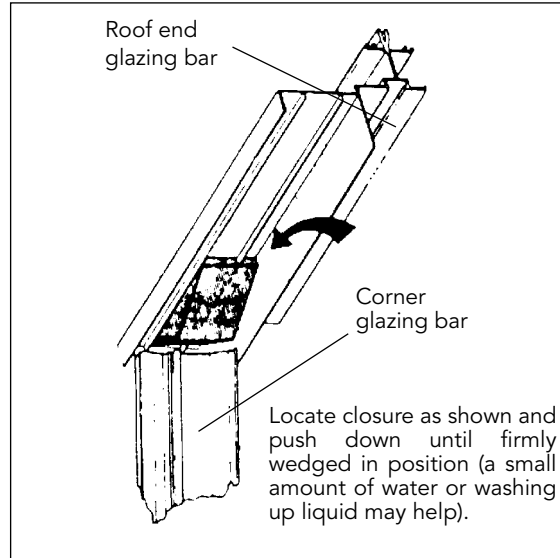
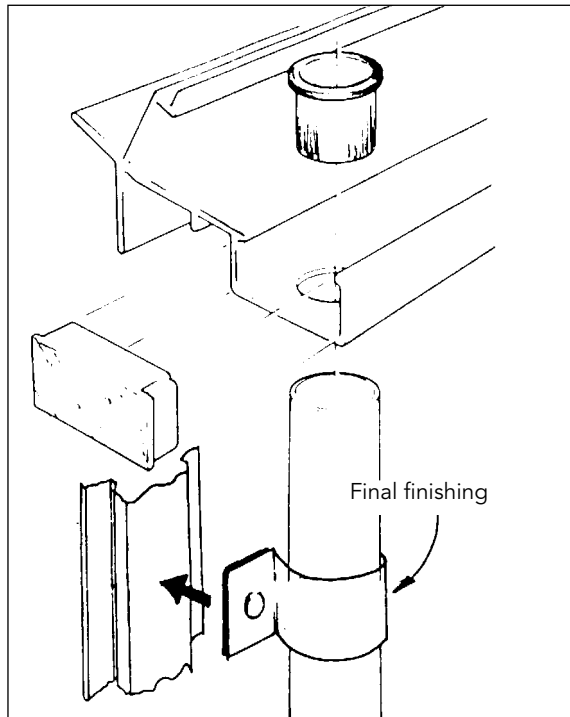

85. Finally, when the building is complete, fit roof end glazing bar closure and apply silicon sealer (as shown below).

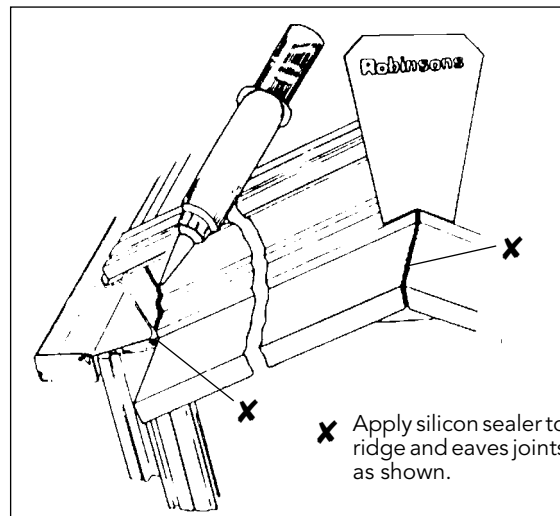

NOTE: If you are not fitting an extension, please turn to page 14.

EXTENSIONS

If you have been supplied with an extension, your main building will differ in that the roof end and corner glazing bars (on the end to which the extension will be fitted) are replaced with standard side and roof glazing bars from the extension module kit. These should be fitted using long bolts throughout. In addition, it will be necessary to slide additional bolts into each side bar and roof bars (5 for Rosette and Regal, 4 for Royale, and 3 for Regent) to accommodate a reinforcing channel. Continue therefore erecting the main building frame, using the main instructions up to 29. When the main frame is complete, continue as follows.

NOTE: If you are fitting a partition at the front between two sections, refer to the partition section.

86. Identify and fit gutter, base rail and ridge connecting plates (Nos. 60, 61 & 63, ID Chart). When fitting extension ridge, gutter and side cills, the 586mm hole centres at one end of the component must abutt the main greenhouse. The glazing bar centres will then be correct at 620mm

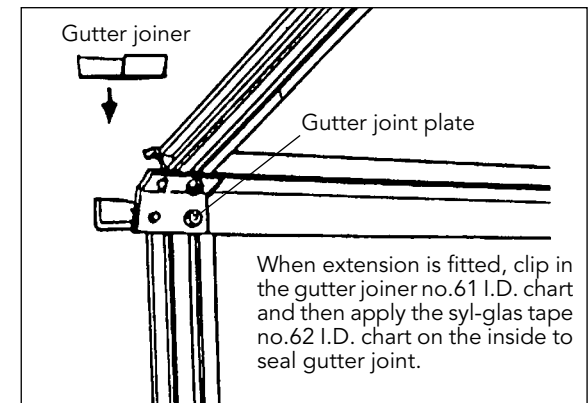

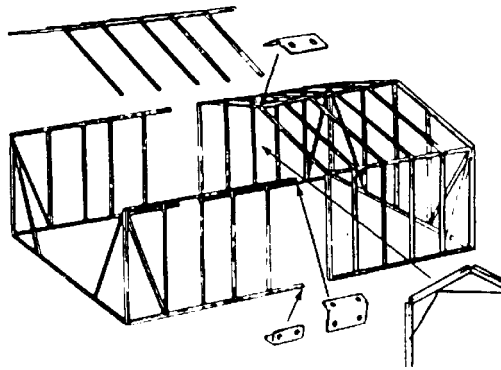
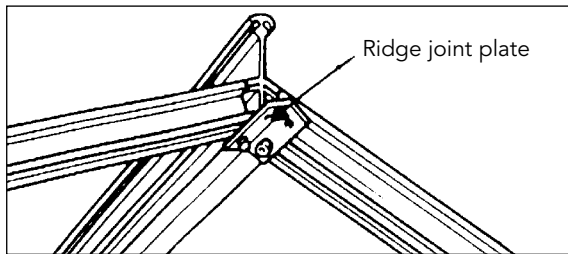
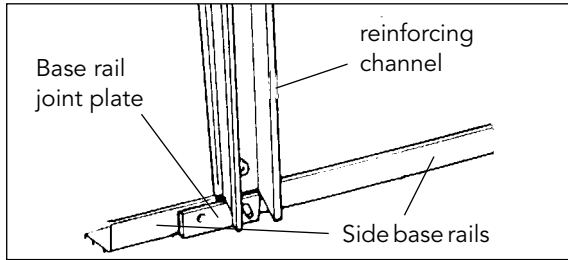

- 87. Identify and fit reinforcing channel (No.64, ID Chart) to side and roof glazing bar using previously inserted bolts.
- 88. Fit eaves joint plates (No. 65, ID Chart) using short bolts.
- 89. Fit square section reinforcing frame (No. 66, ID Chart) using M6 x 35mm bolts (No. 67, ID Chart).
- 90. Assemble the extensions using established procedure.

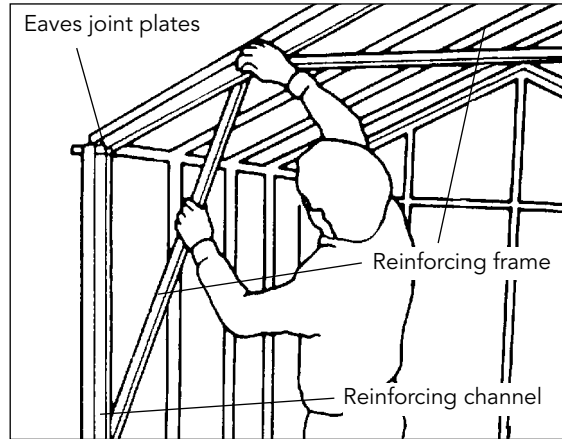

- 91. Offer up extension to main building and secure with short bolts.
Your greenhouse is now ready to be secured in position and glazed.

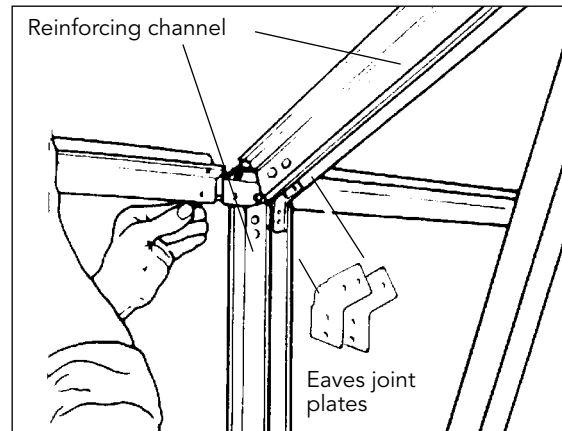

PARTITIONS

Partitions may be fitted at any glazing bar position in the greenhouse. All that is required is to fit special roof-end and corner glazing bars in lieu of the conventional glazing bar, taking care to face the way round required. The special roofend and corner glazing bars are provided with a slot to allow the ridge, gutter and base rail to pass through. If however the partition is required on a joint between a main

building and extension module, the reinforcing frame normally fitted between two buildings is no longer used. It is imperative in this situation that the partition faces the main building. (See diagram).

- 92. Build up partition as a plain end after deciding on the floor position. (See page 8 for door assembly).

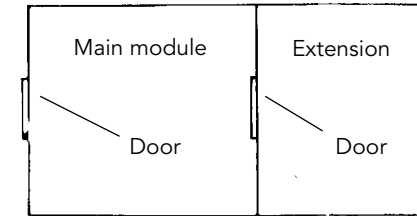

METHOD OF ERECTION: ROYALE

Royale 8ft model single door

- 93. Clad as for plain end. Because the door is plain (no handle or lock fitted), it can be made to slide in either direction. After deciding which way you prefer, glaze the gable end, leaving the two top shapes. Fit single header to track (inner and outer) and position on top of door posts. Secure with attachment plates using a special double one between the two. You can then complete the glazing not forgetting the 'Z' trim. Make up the door drilling two 6mm holes for the handles in the side required.

Shape A	Shape D	Shape I	Shape A
610		610	610
X		X	X
1374		1374	1374
610 x 305		610 x 305	610x305

NB. Door can be fitted in either middle bay.

METHOD OF ERECTION: ROSETTE

Rosette 10ft model – single door

94. Clad as for plain end. Because the door is plain (no handle or lock fitted), it can be made to slide in either direction. After deciding which way you prefer, glaze the gable end, leaving the two top shapes. Fit single header to track (inner and outer) and position on top of door posts. Secure with attachment plates using a special double one between the two. You can then complete the glazing not forgetting the 'Z' trim. Make up the door drilling two 6mm holes for the handles in the side required.

Shape E	Shape F	Shape G	Shape H	Shape F	Shape E
305	610		610	610	305
X	X		X	X	X
1374	1374		1374	1374	1374
305 X 305	610 X 305		610 X 305	610 X 305	305 X 305

NB. Door can be fitted in either middle bay.

METHOD OF ERECTION: ROSETTE & REGAL

Double door

NOTE: Doors must be slid into the top track and erected as a complete unit.

95. Clad as for door end (see 10). Assemble inner and outer shortened partition door tracks and header. Identify special door track support angles (No. 68, ID Chart) and fit to roof end bars, then fit door track to these. Slide door on as you go. Glazing can then be completed above the door (see 11). It would be advisable to complete all this work before glazing the main structure.

SECURING THE BASE WITH SOIL

BASE ANCHORS.

96. When the greenhouse is in its final position, identify the soil base anchors (No. 16, ID Chart). Place one anchor per glazing bar on the sides. (Only one anchor required at each corner - not two).

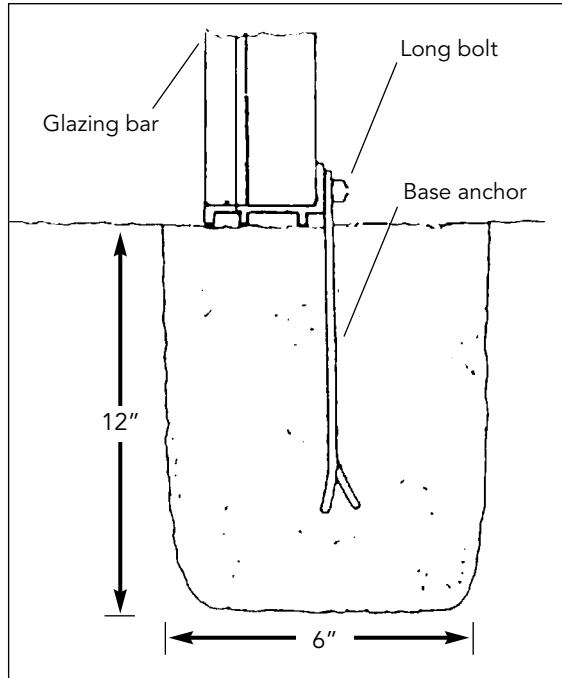

Then dig out a hole below each chosen glazing bar 6" X 6" X 12" and secure the soil anchors in position. Concrete in each anchor as shown and allow to set.

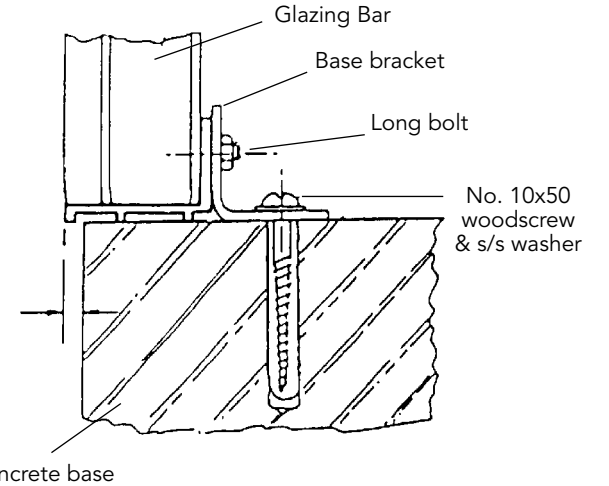

SECURING THE BASE WITH CONCRETE

BASE BRACKETS.

97. When the greenhouse is in its final position, check that it is square, diagonals are equal and the base rail overhangs 7mm all around (as shown).

Position the base brackets at the base of each glazing bar on the ends, and every other on the sides. (Only one bracket required at each corner-not two).

Secure the base bracket to the glazing bar (as shown) through slotted hole in bracket, push the bracket down to touch the concrete and tighten nut.

Drill through hole in bracket with a 7mm masonry drill to a depth of 50mm.

Insert a rawlplug and secure with a wood screw and washer (as shown).

The Regal is Robinsons new 12ft (3836mm) wide greenhouse with lengths from 8ft (2632mm) upwards in 2ft (610mm) increments. There is no limit on the length.

Ridge and eave brackets are applied to every set of glazing bars and extra structural support is added to the door gable by 8ft (2632mm) purlin bar. Fixed to the glazing bars with slide in nuts and bolts.

If extensions are added (these being 6ft (1860) models), a strengthening 'A' frame must be attached.

It is essential that a large greenhouse of this span has a continuous concrete or brick perimeter footing.

DOOR FIXING

When fixing the door top track bar, it is necessary to drill holes in door track into glazing bar, and fix with long self tap screws (No.8 x 3/4).

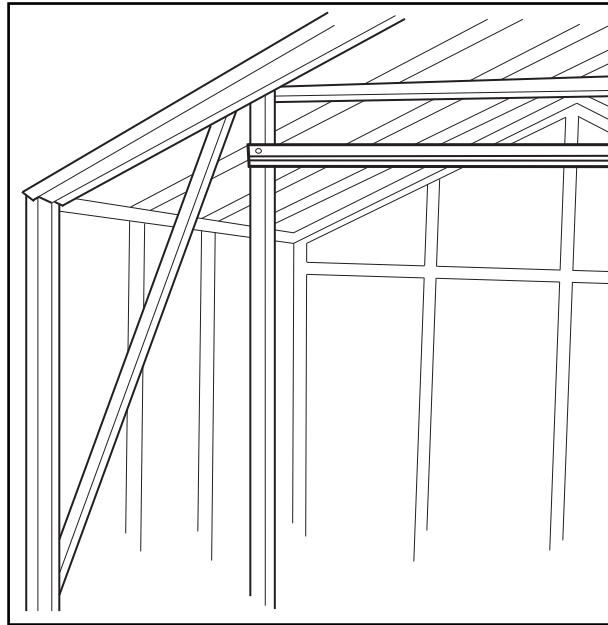

NB. Longer self tap screws for door track No.8 x 3/4"

SIZE • REGAL 12

MODEL	Normal size	'A' Frame	Max Span
8 + 6	14	One	8'
10 + 6	16	Two	6'
12 + 6	18	Two	6'
8 + 6 + 6	20	Two	8'
10 + 6 + 6	22	Three	6'
12 + 6 + 6	24	Three	6'

A 10' and 12' long house each only
'A' Frame as standard.

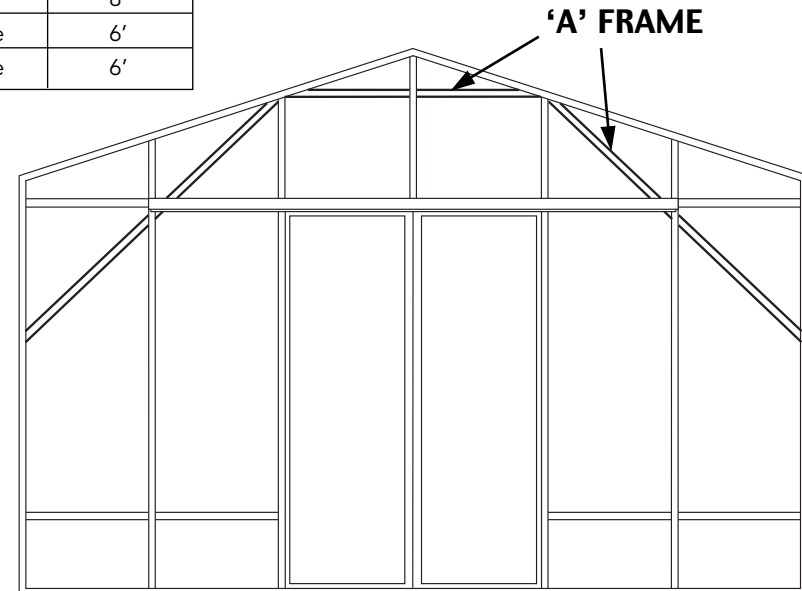

Regal 12 x 24 Example

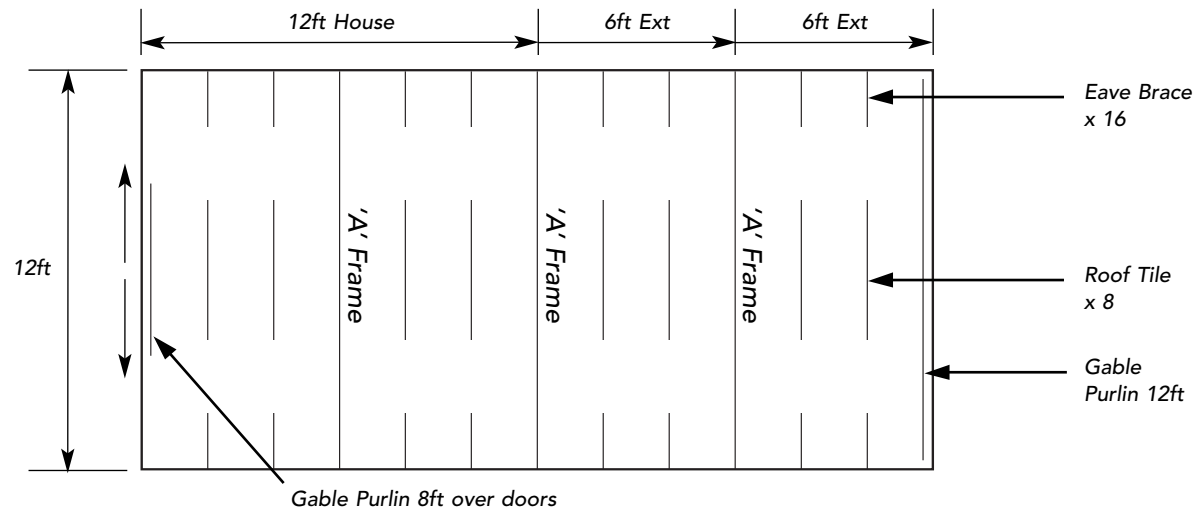

I.D. Chart

1. Ridge member R118

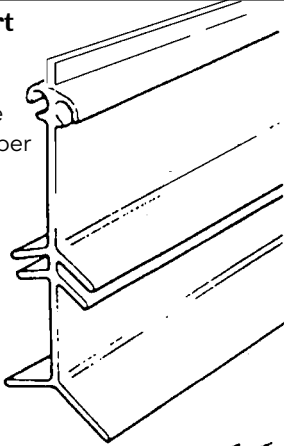

2. Glazing bar R112

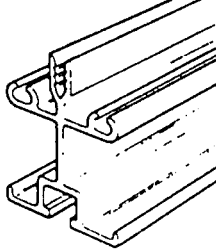

3. Roof end glazing bar R120

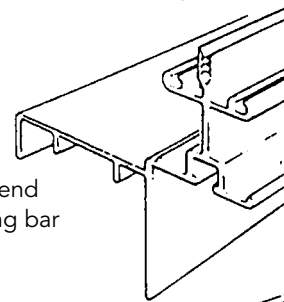

4. Eaves gutter R128

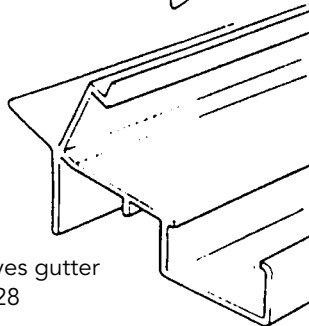

5. PVC glazing strip D231

6. Short square headed bolt F5002 nut F5006



7. Apex gusset plate D111

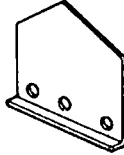

inside grooves

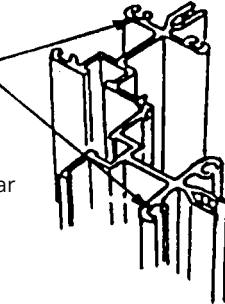

8. Corner glazing bar D048

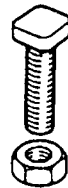

9. Long square headed bolt F5003 nut F5006

10. Side base rail R125

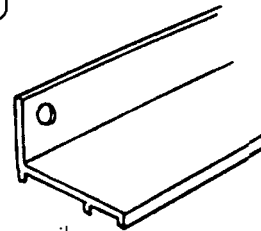

11. Door and plain end gable base rail R174 Door guide (door end only) D860 S/D, D861 D/D

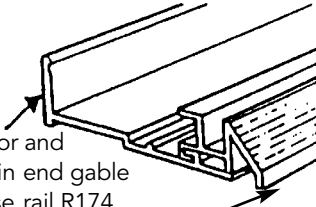

12. Plain end purlin member R005

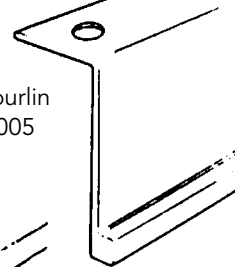

13. Bar cap cover R317

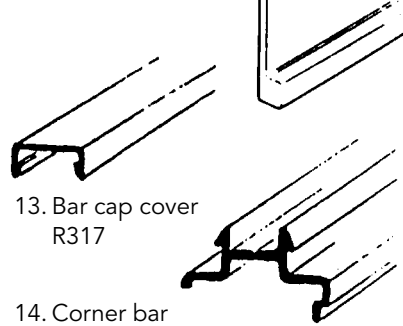

14. Corner bar capping R318

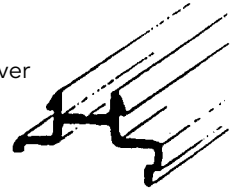

15. Standard bar capping R316

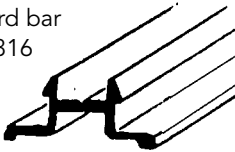

16. Base anchor D106



17. No 8 x 12mm self tapping Pozidrive screws FS6017



18. Vent hinge D866

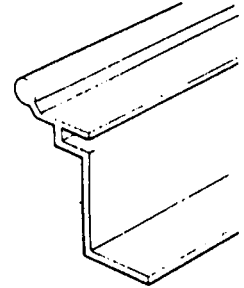

19. Vent side D863

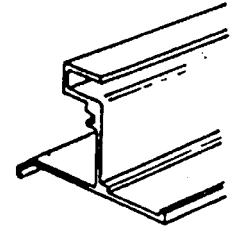

20. Vent cill D862

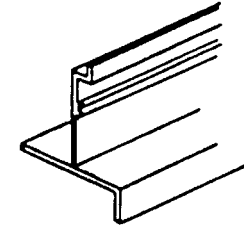

21. Vent stop D220 Screw FS6060

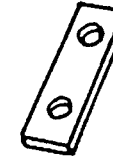

22. Slam rail cleat and base rail joint plate D114

23. Vent closure D205

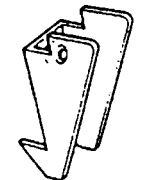

I.D. Chart

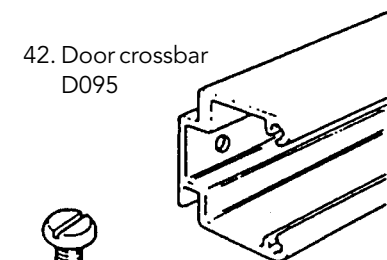
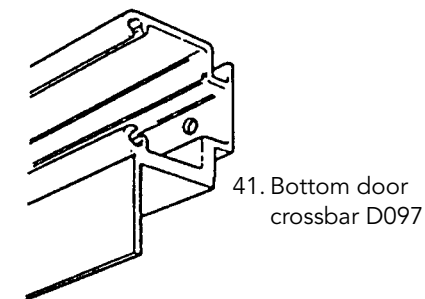
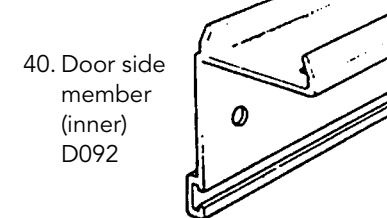
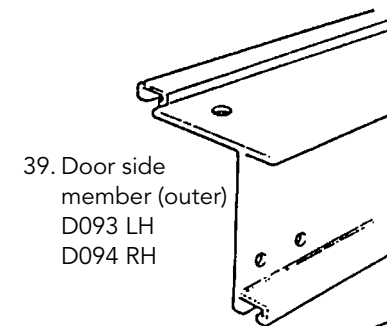
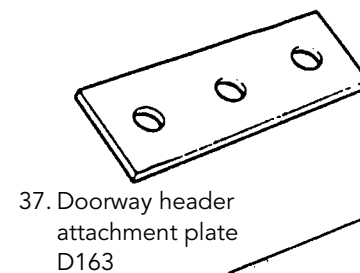
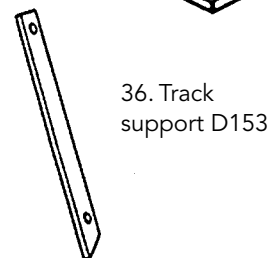
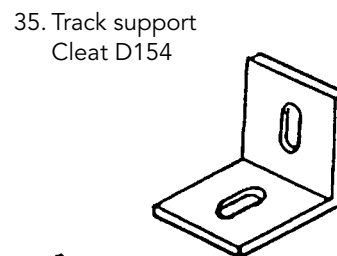
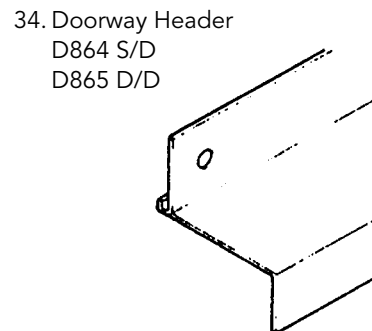
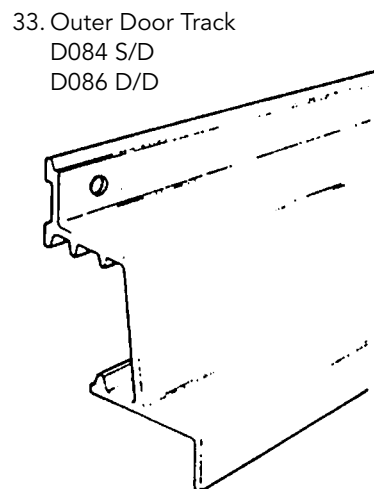
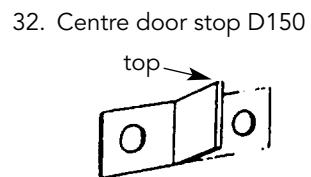
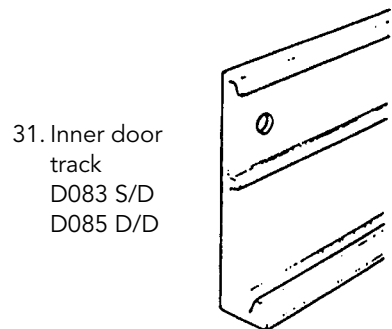
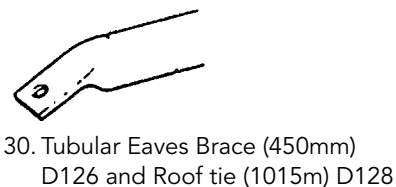
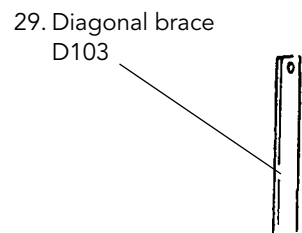
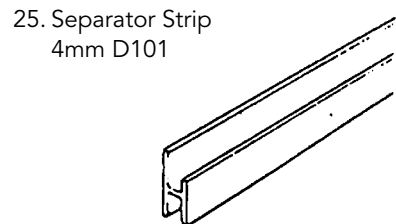
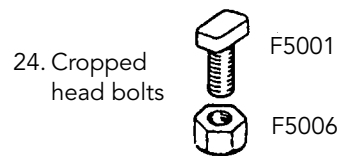

I.D. Chart

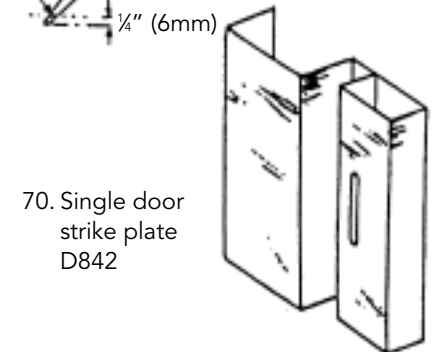
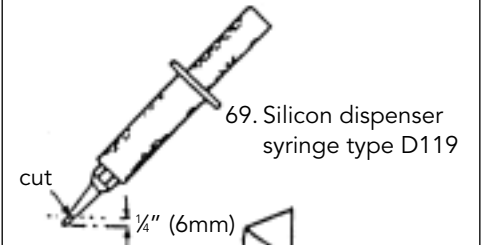
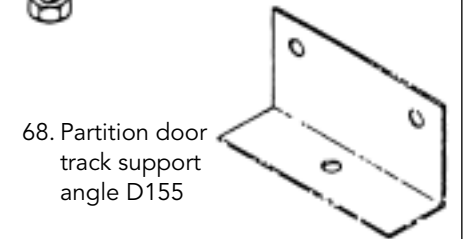
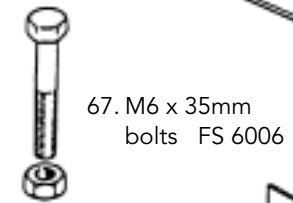
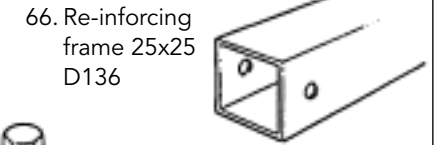
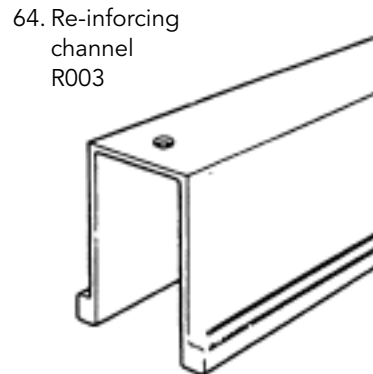
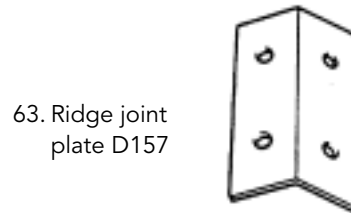
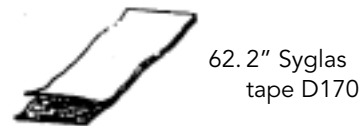
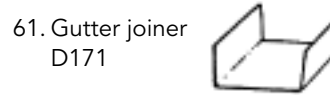
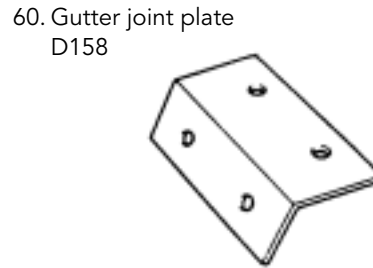
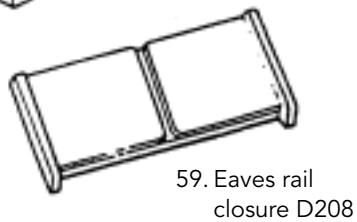
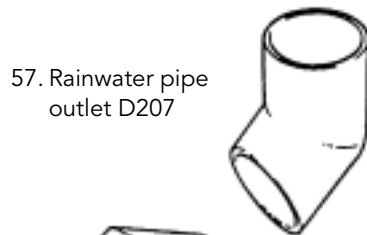
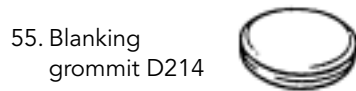
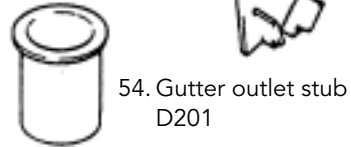
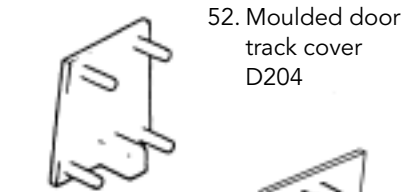
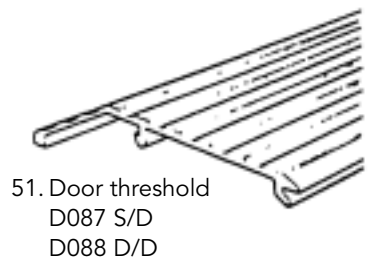
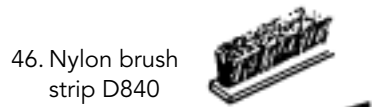
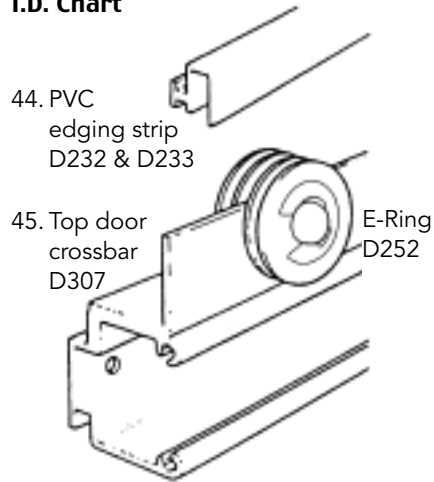

TOUGHENED GLASS ONLY 4mm

Glazing Plans

REGENT

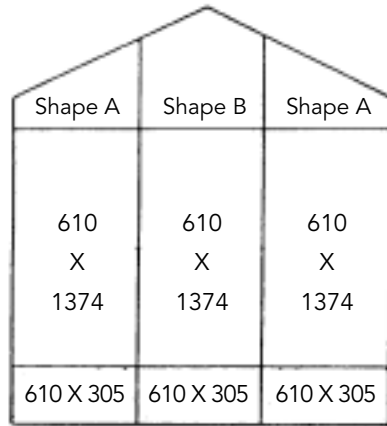

Plain End

6ft Glazing plan

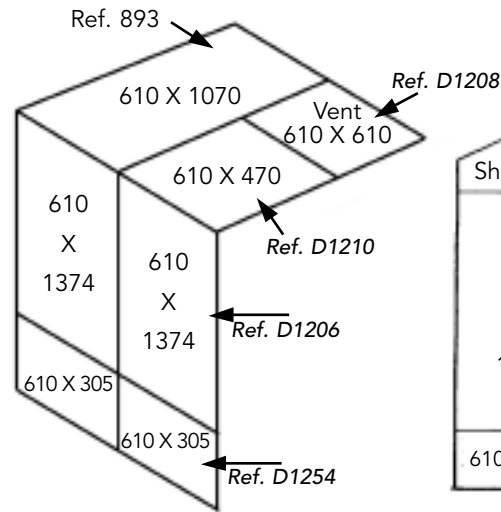

Side/Roof

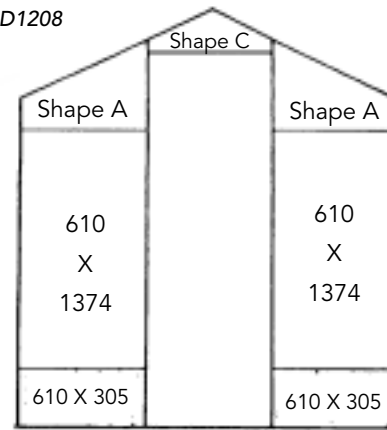

Door End

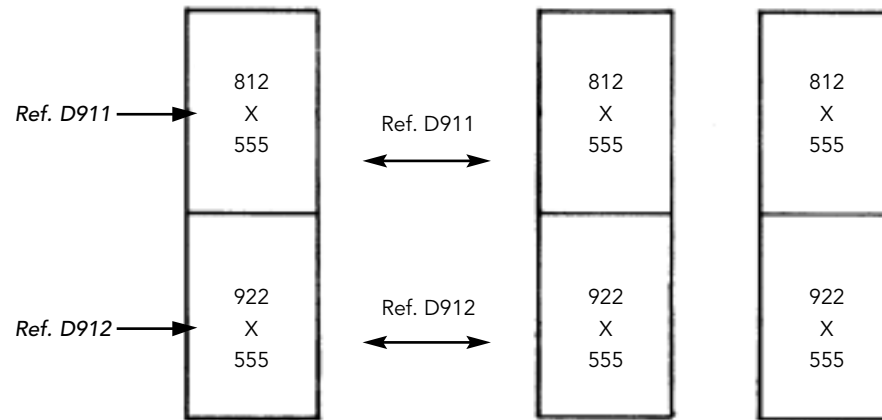

Single Door

Double Door

Measurements in mm.

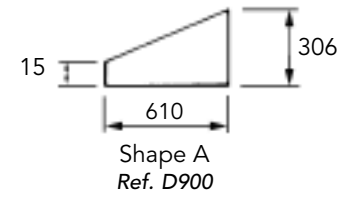

Shape A
Ref. D900

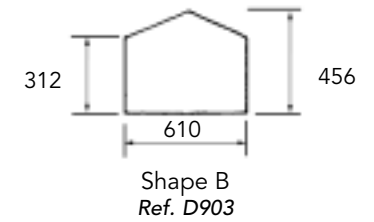

Shape B
Ref. D903

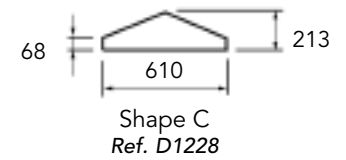

Shape C
Ref. D1228

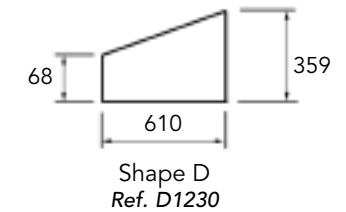

Shape D
Ref. D1230

TOUGHENED GLASS ONLY 4mm

TOUGHENED GLASS ONLY 4mm

Measurements in mm.

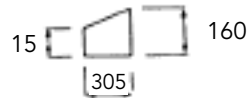

Shape E
Ref. D902

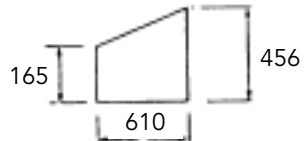

Shape F
Ref. D901

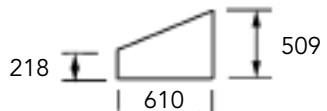

Shape G
Ref. D1236

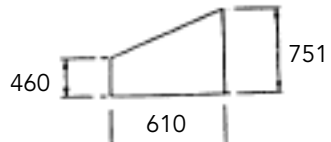

Shape H
Ref. D907

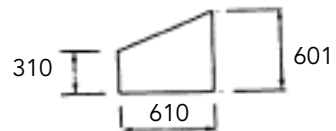

Shape I
Ref. D908

ROSETTE

Shape E	Shape F	Shape H D907	Shape H D907	Shape F	Shape E
305	610	610	610	610	305
X	X	X	X	X	X
1374	1374	1374	1374	1374	1374
305 X 305	610 X 305	610 X 305	610 X 305	610 X 305	305 X 305

Plain End

10ft Glazing plan

ROYALE

Shape A	Shape I D908	Shape I D908	Shape A
610	610	610	610
X	X	X	X
1374	1374	1374	1374
610 X 305	610 X 305	610 X 305	610 X 305

Plain End

8ft Glazing plan

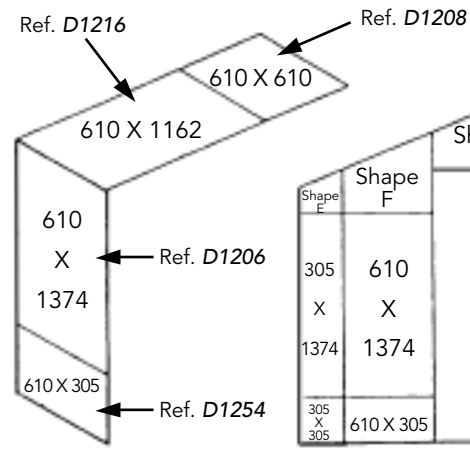

Side/Roof

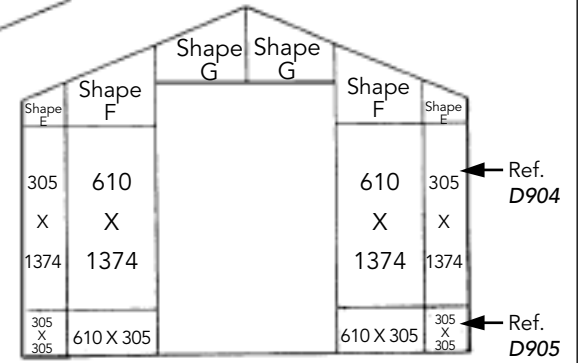

Door End

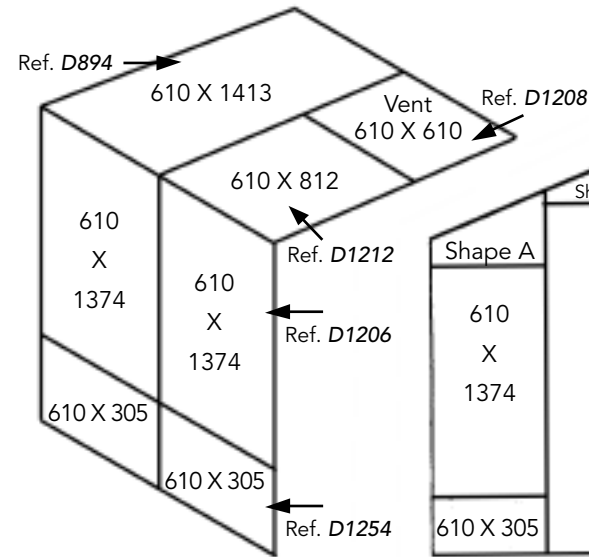

Side/Roof

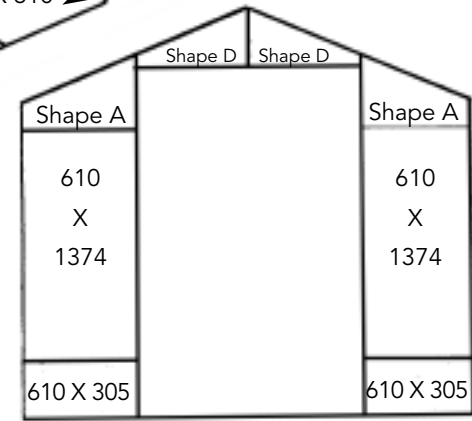

Door End

TOUGHENED GLASS ONLY 4mm

Glazing Plans

REGAL

12ft Glazing plan

Shape A	Shape I	Shape J	Shape J	Shape I	Shape A
610 X 1374	610 X 1374	610 X 1374	610 X 1374	610 X 1374	610 X 1374
610 X 305	610 X 305	610 X 305	610 X 305	610 X 305	610 X 305

Plain End

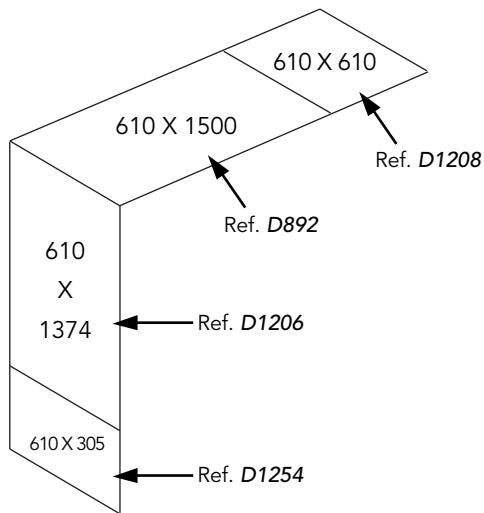

Side/Roof

Shape A	Shape I	Shape K	Shape K	Shape I	Shape A
610 X 1374	610 X 1374			610 X 1374	610 X 1374
610 X 305	610 X 305			610 X 305	610 X 305

Door End

Measurements in mm.

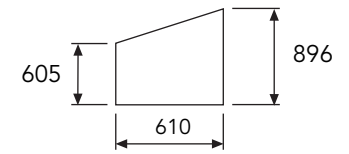

Shape J
Ref. D890

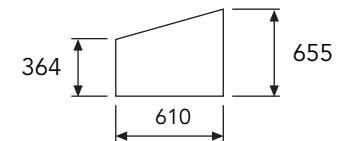

Shape K
Ref. D891

TOUGHENED GLASS ONLY 4mm

3-Slat - 11" · 28cm Deep Shelf

May be fixed to aluminium greenhouse glazing bars or direct to a wall.

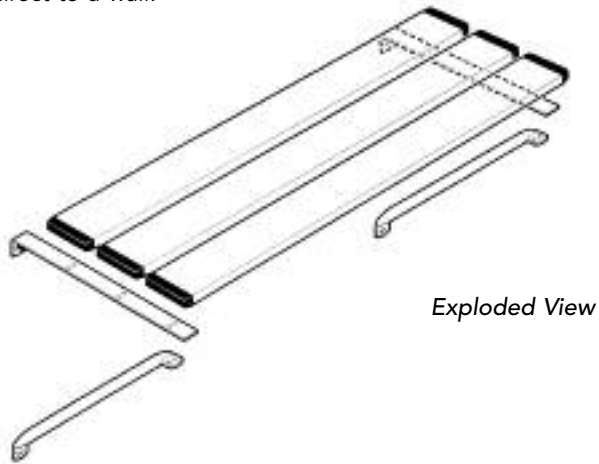

ONE

Fix the horizontal brackets to aluminium greenhouse glazing bars spaced at approx. 2ft (60cm) centres using cropped-head bolts. Ensure these are correctly engaged in the nut groove before tightening. Ensure adjacent brackets are level.

Temporarily secure the top of each tubular brace to the end of the horizontal bracket. Position and fix the lower end of each brace so that the bracket is level.

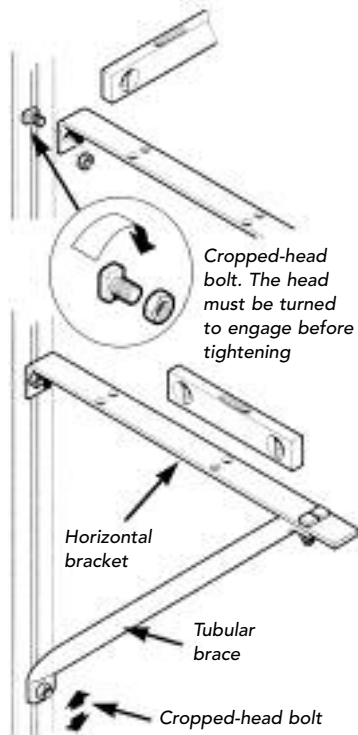

TWO

Feed bolts as required into central groove on underside of slat.

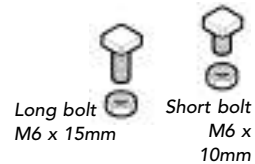

Bolt requirement:
Front slat - 1 long bolt each end, plus 2 long bolts for each mid-bracket.
Other slats - 1 short bolt for each bracket.

Secure each slat in turn starting from one end (see detail A). On front slat ensure that the long bolts go through the tubular braces. A short bolt (beyond end of slat) completes fixing of outer braces.

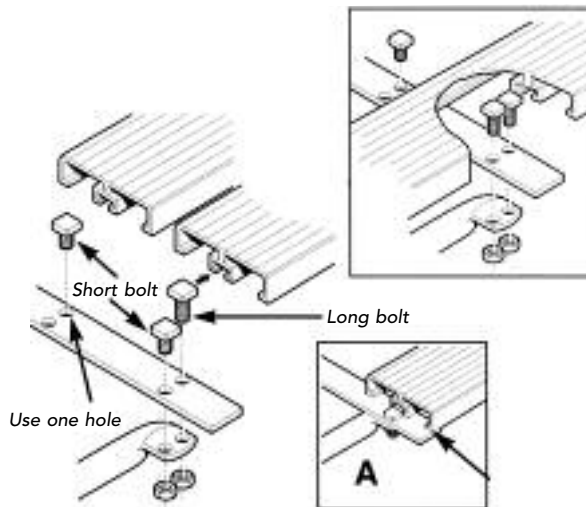

THREE

Joining two sections

The shelf may be easily extended as required by joining slats on one bracket.

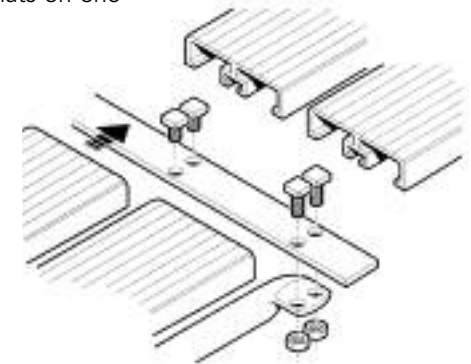

FOUR

At ends of runs

Push end bungs into slat to finish.

Remove cut out, with sharp knife, on bung for front slat to clear bolt head.

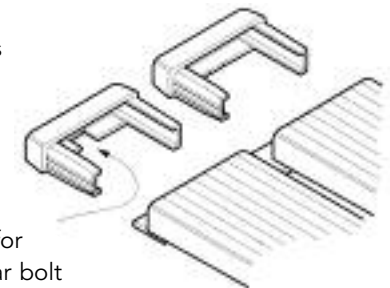

7-Slat - 25" · 63.5cm Deep Shelf

May be fixed to aluminium greenhouse glazing bars or direct to a wall.

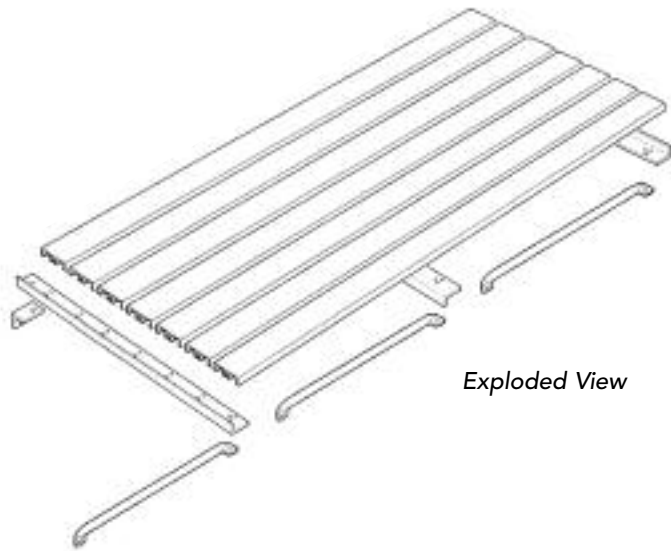

Greenhouse Fixing

Using the nut groove in aluminium glazing bars at approx. 2ft (60cm) centres. Use the appropriate cleat as indicated.

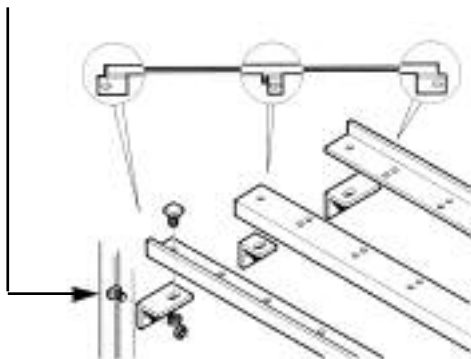

ONE

Fix the wall cleats using cropped-head bolts (ensuring that they are correctly fully engaged in the nut groove) or using wall plugs and screws as appropriate. Ensure adjacent brackets are level.

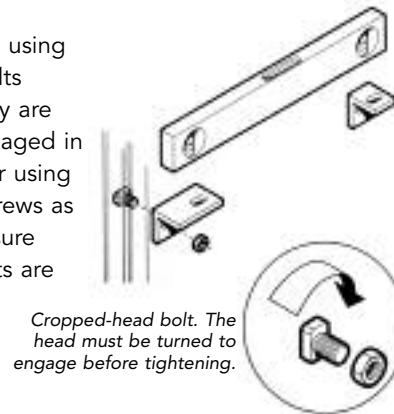

TWO

Fix the horizontal brackets ensuring the flanges close off the ends of the slats. Secure the top end of the tubular brace to the single hole near the end of the bracket. Position and fix the lower end of the brace so that the bracket is level.

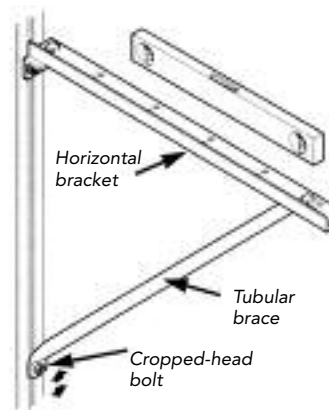

THREE

Secure slats to the horizontal brackets as shown. The bolt heads slot into the central groove in the underside of each slat. Feed in extra bolts, one for each end and one for the centre.

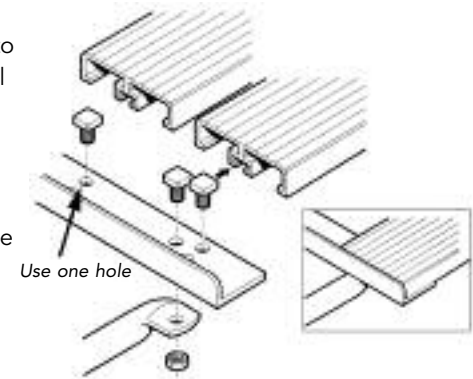

FOUR

The central horizontal bracket is mounted with flat top on to which the slats are fixed. The second of each pair of holes is only used for joining slats (see below). Once all the slats have been assembled, check for squareness and then securely tighten all nuts with a 10mm spanner or nut driver.

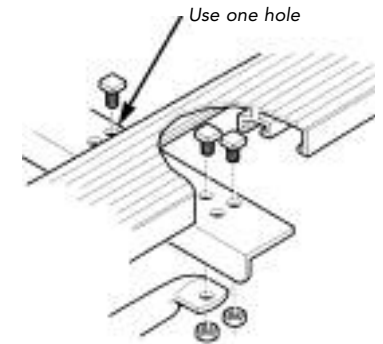

Fixing into greenhouse corners where there is no nut groove

The glass must be removed prior to drilling 7mm holes in the glazing bar to accept the offset cleat and tubular brace. This will provide clearance for typical greenhouse bracing. In rare cases it may be necessary to shorten the length of the slats using a hacksaw.

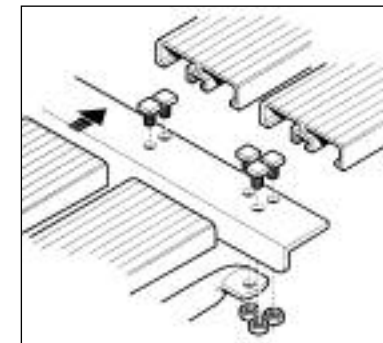
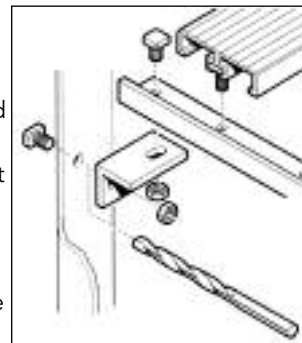

Joining two sections of staging

The offset cleat at the join has to be replaced with small intermediate cleat. The horizontal bracket is then turned over so that the flat top supports the end of the two sets of slats. Secure each slat with a bolt.

10-Slat - 37" · 94cm Deep Shelf

May be fixed to aluminium greenhouse glazing bars or direct to a wall. Extra support is supplied for this staging, It is fixed to the side glazing bar and hooked into the

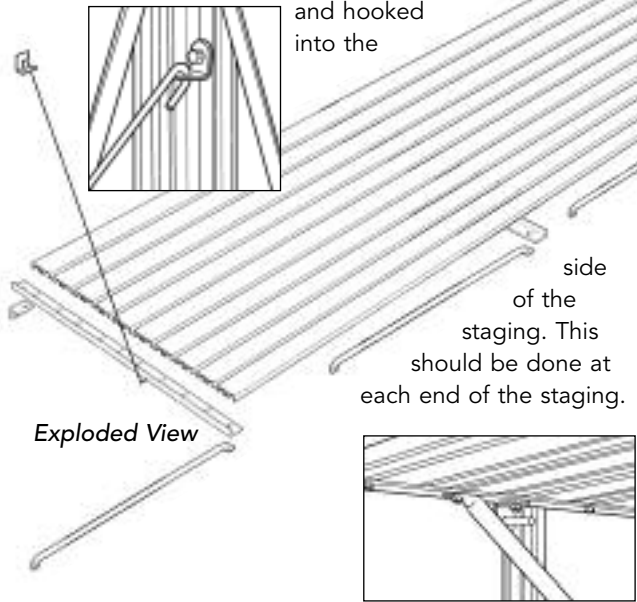

Greenhouse Fixing

Using the nut groove in aluminium glazing bars at approx. 2ft (60cm) centres. Use the appropriate cleat as indicated.

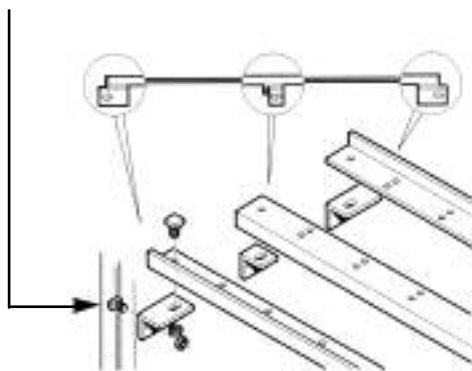

ONE

Fix the wall cleats using cropped-head bolts (ensuring that they are correctly fully engaged in the nut groove) or using wall plugs and screws as appropriate. Ensure adjacent brackets are level.

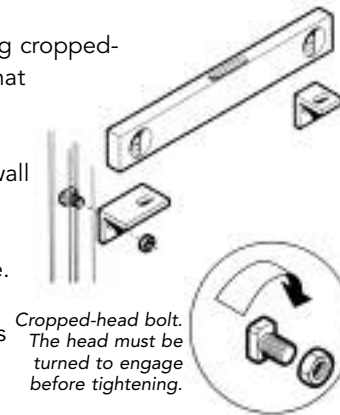

TWO

Fix the horizontal brackets ensuring the flanges close off the ends of the slats. Secure the top end of the tubular brace to the single hole near the end of the bracket. Position and fix the lower end of the brace so that the bracket is level.

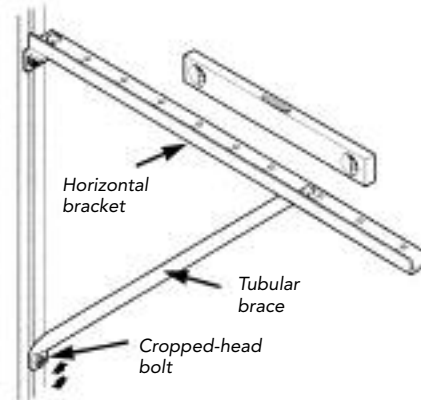

THREE

Secure slats to the horizontal brackets as shown. The bolt heads slot into the central groove in the underside of each slat. Feed in extra bolts, one for each end and one for the centre.

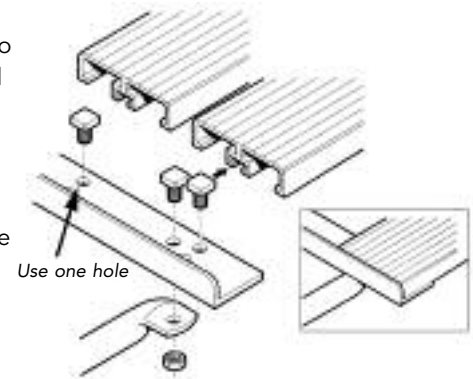

FOUR

The central horizontal bracket is mounted with flat top on to which the slats are fixed. The second of each pair of holes is only used for joining slats (see below). Once all the slats have been assembled, check for squareness and then securely tighten all nuts with a 10mm spanner or nut driver.

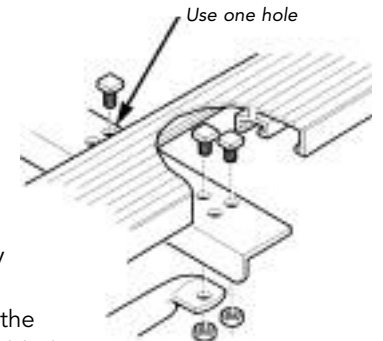

Fixing into greenhouse corners where there is no nut groove

The glass must be removed prior to drilling 7mm holes in the glazing bar to accept the offset cleat and tubular brace. This will provide clearance for typical greenhouse bracing. In rare cases it may be necessary to shorten the length of the slats using a hacksaw.

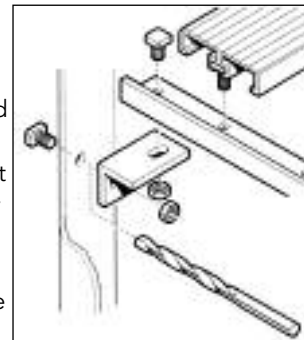

Joining two sections of staging

The offset cleat at the join has to be replaced with small intermediate cleat. The horizontal bracket is then turned over so that the flat top supports the end of the two sets of slats. Secure each slat with a bolt.

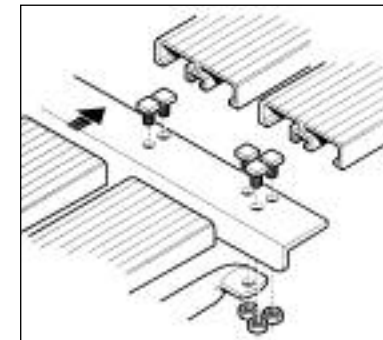

Robinsons Louvre Installation Instructions

D361 Louvre Kit

INSTALLATION

- 1 Screw self-tapping screws through holes in the top and bottom cill members into the 'C' groove of the side jambs to form a complete frame.
- 2 From outside the greenhouse, fit the frame in place, fixing into position using the plastic bar caps and screws.
- 3 Open the louvre and slide glass blades into position from inside the greenhouse. To avoid excessive movement of glass, bend the retaining clips so that the louvre blade is firmly gripped.

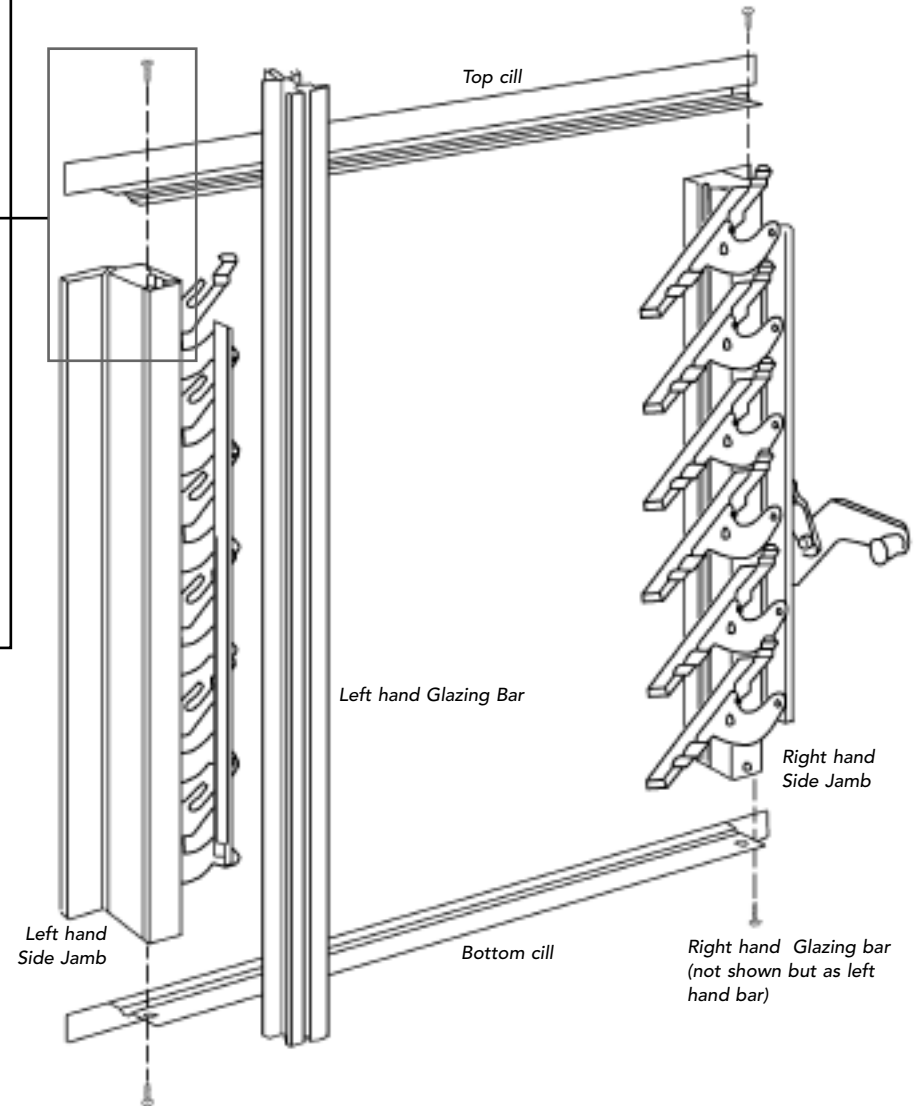
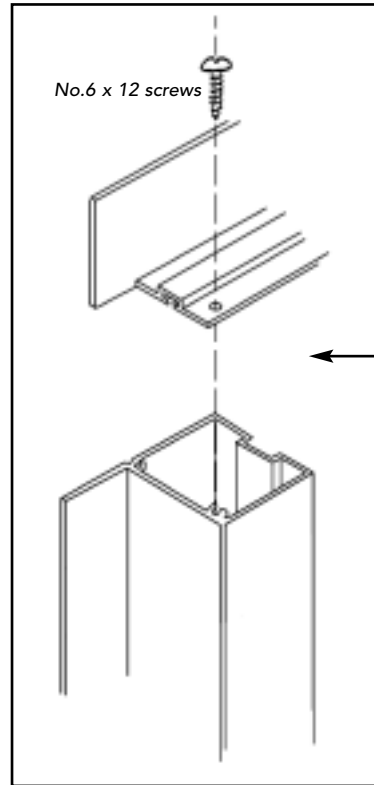

CONTENTS OF KIT

Part No.	Description	No. Required
-	Instructions	one
D168	Louvre jamb set	one
D166	Louvre side member	two
D165	Louvre top/bottom (rubber fitted)	one (pair)
D362	Louvre smalls pack consisting of:	
	FS 6013 N0.6 x 12 self-tapping screws	four
D729 T/G	Louvre glass - 100 x 525mm (4mm thick)	six

Robinsons Right Angle Corner Plates & Partition Clearance Adaptor Assembly Instructions

Partition Clearance Adaptor

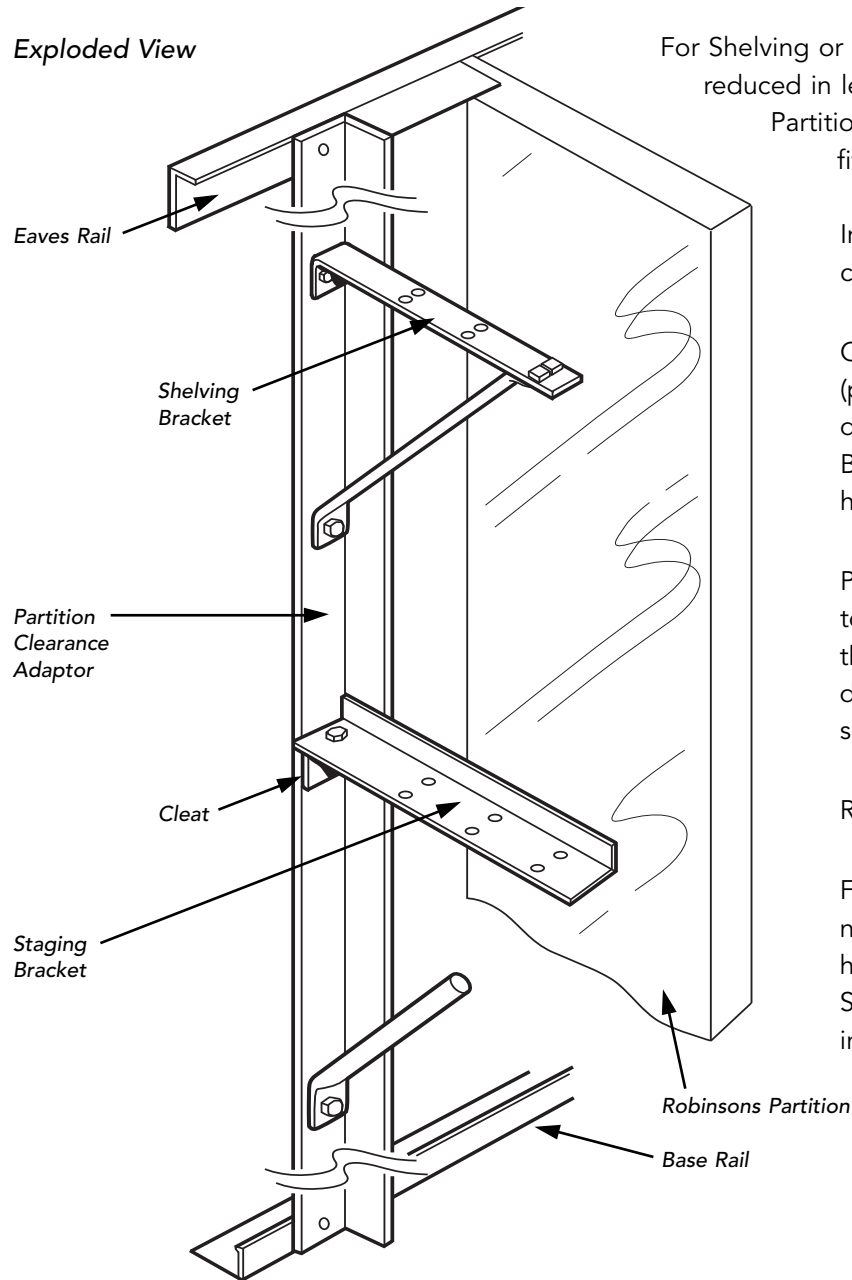

For Shelving or Staging which needs to be reduced in length to clear a Robinsons Partition/Sliding Door it is necessary to fit the Partition clearance adaptor.

Insure you leave sufficient clearance for the sliding door.

Check adaptor for being upright (plumb) and drill 7mm (1/4") diameter holes in Eaves Rail and Base rail and secure with square head bolts.

Position Shelving/Staging brackets to your required height and drill the Partition adaptor, 7mm (1/4") diameter hole, securing with square head bolts.

Reduce length of Slats to suit.

For 10 Slat Staging only you will need to drill a 7mm (1/4") diameter hole for fixing the Rod Cleat and Support Rod (see main Staging instructions)

Right Angle Corner Plates

For Right Angle Joining of Slats slide square head bolts into Slat 'A' (one per slat to be joined). Slide one square head bolt (per Slats 'B') and secure with Slat corner Joining Plate on underside.

Check space between Slats are correct and that Slats 'B' are hard up to Slat 'A' prior to tightening the bolts.

NOTE:

You may have to reduce the length of Slats 'B' to suit.

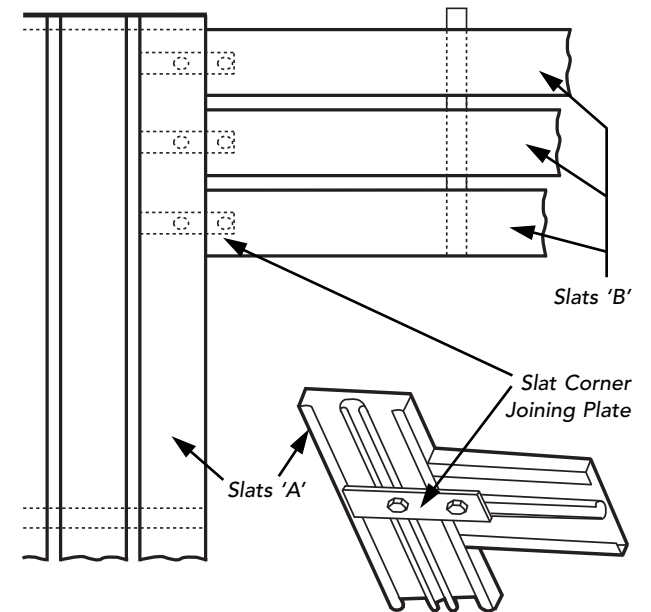

Underside View

Robinsons 'A' Frame Adaptor Assembly Instructions

Shelving

When Shelving extends past or ends at an 'A' Frame reinforcing channel.

Fix top slope bracket to horizontal bracket with square head bolts and insert the assembly fully inside the 'A' Frame to your required height. Check for level and then drill two 7mm (1/4") diameter holes "H" (as shown Fig. 1).

Check again for height and level prior to tightening the bolts to clamp the brackets in position.

It may be necessary to lightly file the edge of brackets for ease of fitting inside 'A' Frame.

Fig. 1

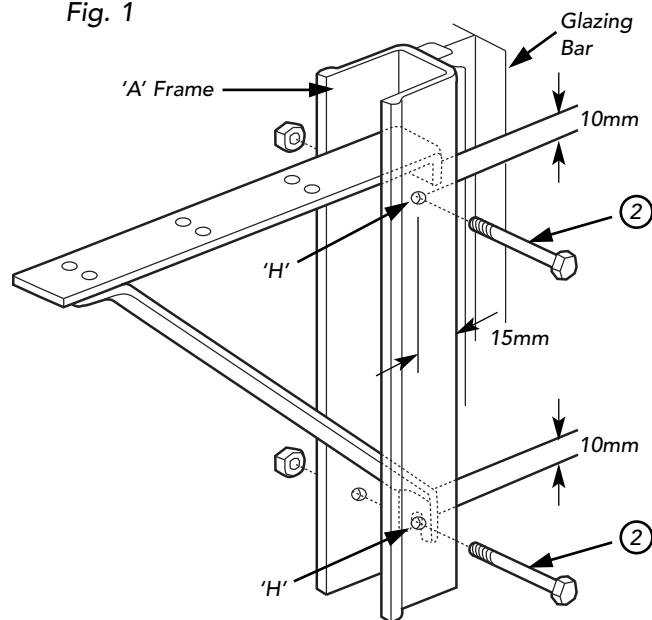

Staging

Staging extending past an 'A' Frame as drawn (see note E for ending at an 'A' Frame).

1. Reduce length of Staging mounting bracket, at an 'A' Frame by 45mm cut opposite end to rounded corner 'R'.
2. Fix cleat to 'A' Frame adaptor (1) with square head bolt and then insert the assembly inside the 'A' Frame (as shown Fig. 2) to your required height. Check bracket for height and level again, then drill a 7mm (1/4") diameter hole 'H' through 'A' Frame and adaptor and secure with item 2.
3. Fix mounting bracket to cleat (square head bolt).
4. Fit bottom of Tubular Brace to adaptor (1) and the top to mounting bracket (square head bolt) inserting adaptor inside the 'A' Frame. Adjust adaptor position until mounting bracket is level and then drill a 7mm (1/4") diameter hole 'H' through 'A' Frame and adaptor and secure with item 2.
5. If Staging ends at an 'A' Frame use end mounting cleat (4 or 5 on main instructions) with left or right hand mounting bracket positioned with "flange up" to close end of Staging.

Fig. 2

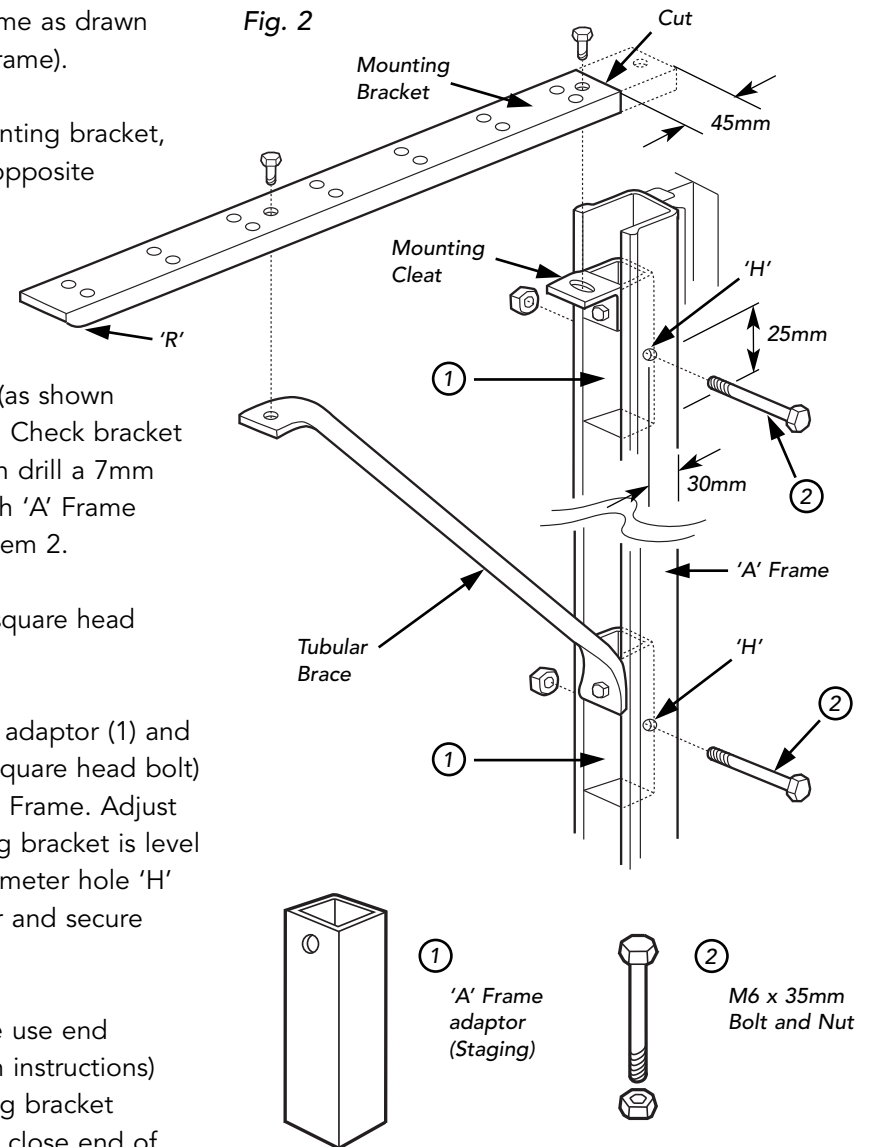



ROBINSONS GREENHOUSES, STATION WORKS, FENNY COMPTON, SOUTHAM CV47 2XB
TELEPHONE 01295 770717 · FAX 01295 770819

Whilst the information contained in this leaflet is accurate at the time of publication, changes in the course of Robinsons policy of improvement through development and design might not be indicated. We point out this fact to avoid any infringements of the Trade Descriptions Act and also to advise that Robinsons Greenhouses reserve the right to change specifications and materials without prior notice. All sizes nominal. All weights approximate.